



ENDURASIGN QUICKFIT FRAME





CONTENTS

PAGE	
3	Features
4	Dimensions and weights
6	Supplementary plate
7	EnduraSign Ballast
8	Wind resistance
9	Wind data scale specifications
10	Durability testing
11	Colour customisations
12	Compactness and lightness
13	Spares and maintenance
14	Recyclability
15	Associated products
16	Contact information





FEATURES

30CM SQUARE MOUNTING FASTENERS AS PER QUICKFIT MINI FRAMES TO ACCEPT THE SAME SIGNFACES

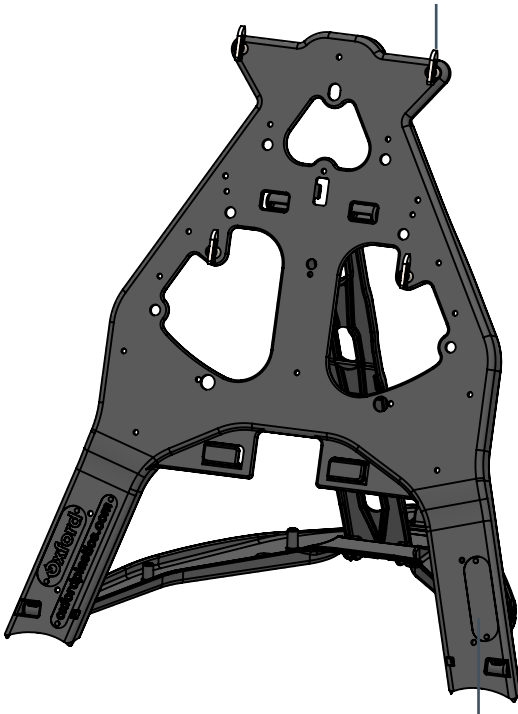

SPACE FOR ENGRAVED CUSTOMER LOGO

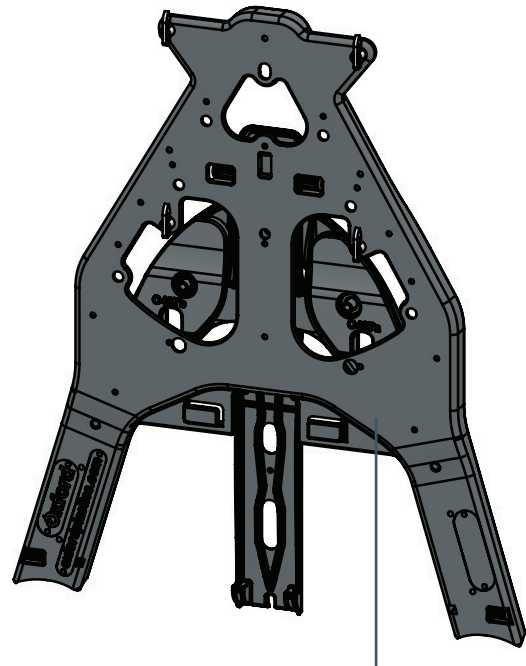

COLLAPSES FLAT

QUICKFIT

30cm square drop lock system compatible with all quickfit faces.

Quickly change faces on site.

Reduce weight and quantity of products in works vehicles.

Damaged reflective signfaces can be easily changed.

DURABLE

Flexible material that won't crack.

Plastic frame will not conduct electricity or rust over lifetime.

Non-metal construction reduces theft.

Does not scratch the inside of works vehicles.

COMPACT & EASY TO USE

Quick to deploy.

Safe and easy to handle with no sharp edges.

EXTRAS

Can be customised with customer logos, MOQ 150.

Available in custom coloured frame, MOQ 150.

EnduraSign Ballasts can be fitted securely for higher windspeed categories.





DIMENSIONS AND WEIGHTS

ENDURASIGN QUICKFIT FRAME 3.3kg / 7.3lbs DEPLOYED

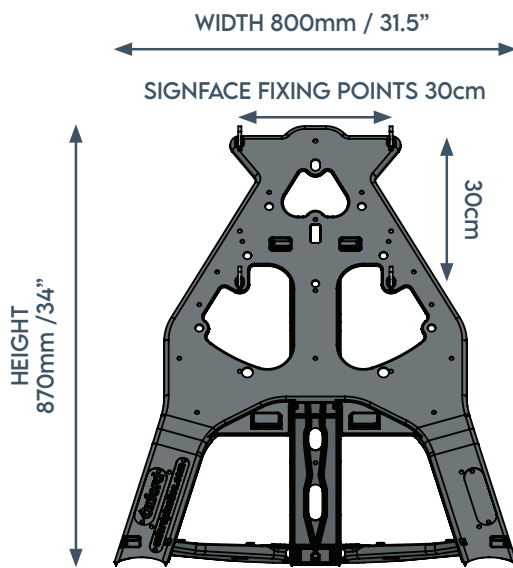

COLLAPSED

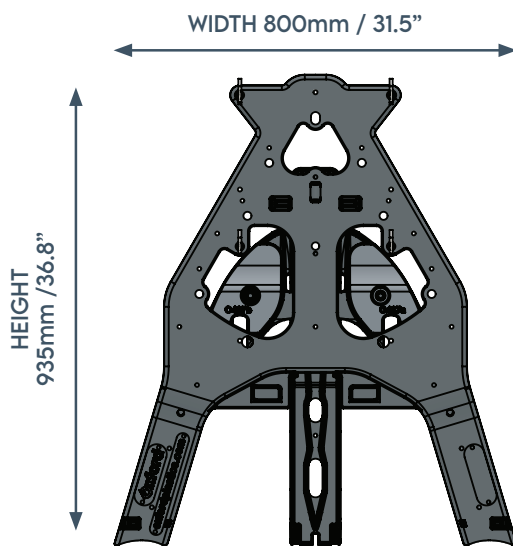

	Product Code	Assembled Weight
EnduraSign QuickFit Frame	O424	3.3kg



DIMENSIONS AND WEIGHTS

ENDURASIGN QUICKFIT ASSEMBLED WITH QUICKFIT SIGNFACE

Quickfit sign faces are compatible with both the EnduraSign QuickFit Frame and the EnduraFrame 1500.

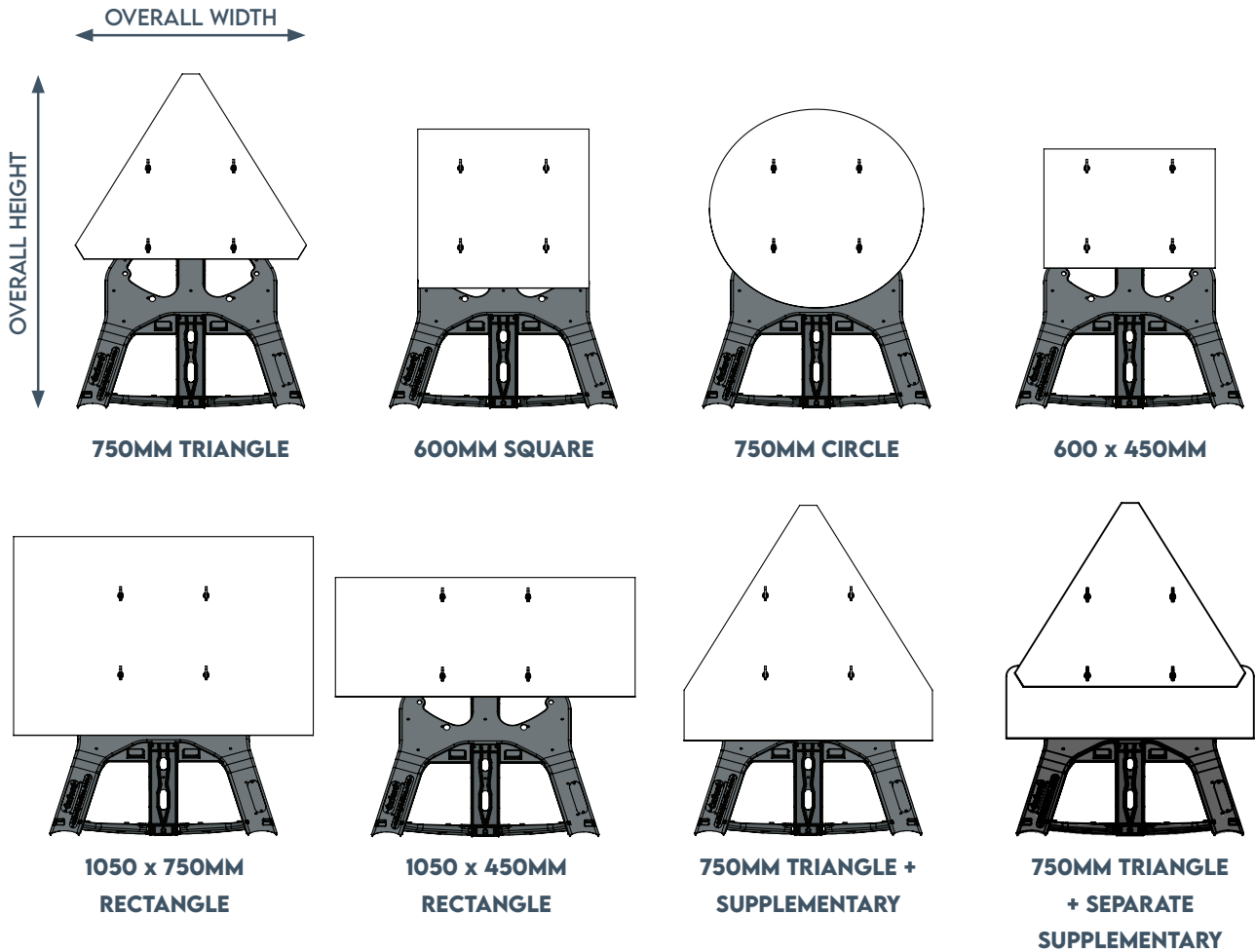

Assembled Signface	Overall Height	Overall Height	Overall Width
	Deployed	Collapsed	
750mm Triangle	1220mm	1305mm	870mm
600mm Square	1050mm	1120mm	780mm
750mm Circle	980mm	1045mm	780mm
600 x 450mm Rectangle	910mm	970mm	780mm
1050 x 750mm Rectangle	1050mm	1120mm	1050mm
1050 x 450mm Rectangle	910mm	970mm	1050mm
750mm Triangle + Supplementary	1200mm	1290mm	870mm
750mm Triangle + Separate Supplementary	1200mm	1290mm	870mm





SUPPLEMENTARY PLATE

The EnduraSign QuickFit Frame is compatible with supplementary plates. Fit with either a single piece sign face and supplementary plate, or a 2 piece sign face and supplementary plate.

SINGLE PIECE OPTION

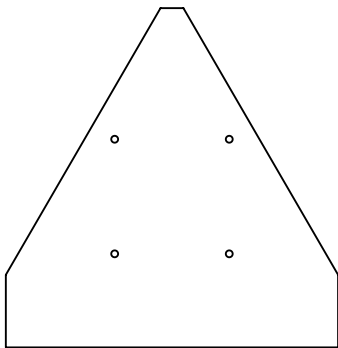

SINGLE PIECE 750MM TRIANGLE + SUPPLEMENTARY PLATE

TWO PIECE OPTION



SEPARATE SUPPLEMENTARY PLATE

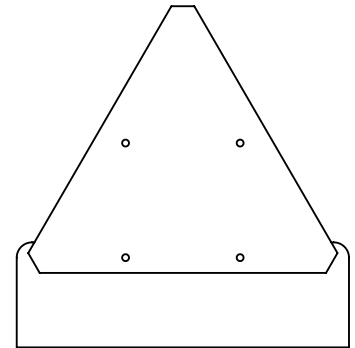

750MM TRIANGLE

TWO PIECE SIGN FACE AND SUPPLEMENTARY PLATE INSTALLATION INSTRUCTIONS

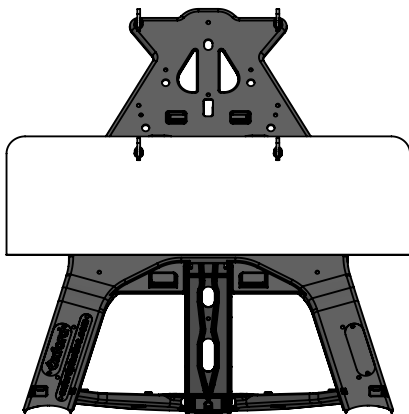

Fit supplementary plate to two bottom drop locks on sign frame.

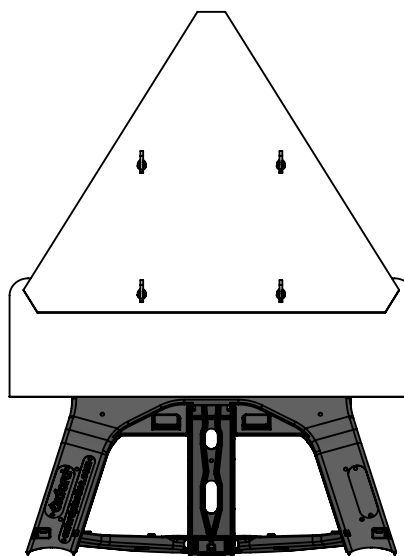

Fit sign face over the top of the supplementary plate.





ENDURASIGN BALLAST

Achieve wind resistance up to Category A (59mph), and reduce defect notices from signs blowing over. See 'WIND RESISTANCE' page for full ballasting details.

The EnduraSign Ballast can be used on all metal and plastic temporary signs to ensure that temporary works stay clearly signposted and street works compliant.

This ballast weight replaces sandbags, it is stackable, quick to deploy and is significantly longer-lasting



Product No.	O426
Width	555mm
Length	407mm
Height	90mm
Weight	10kg
Quantity / Pallet	60
Colour	Black & Yellow

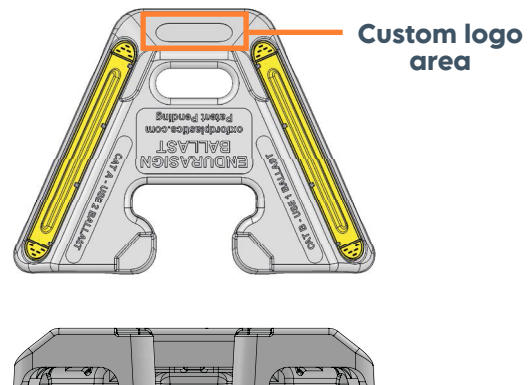

DURABLE & SAFE

Create safe signage installations without using sandbags.

Avoid debris and trip hazards caused by the deterioration of sandbags.

Create highly visible signage installations.

COMPACT & EASY TO USE

Can be easily installed, transported and stored.

Locks onto the EnduraSign to provide stability across a series of different signs in up to Category A winds.

EXTRAS

Adapt and customise ballast with corporate nameplate (120mm x 40mm), MOQ 180.

A closed loop recycling product made of recycled PVC.





WIND RESISTANCE

TRAFFIC SIGNS MANUAL (CHAPTER 8) COMPLIANCE

WITHSTANDS WINDSPEED CATEGORY C WITHOUT ANY BALLAST

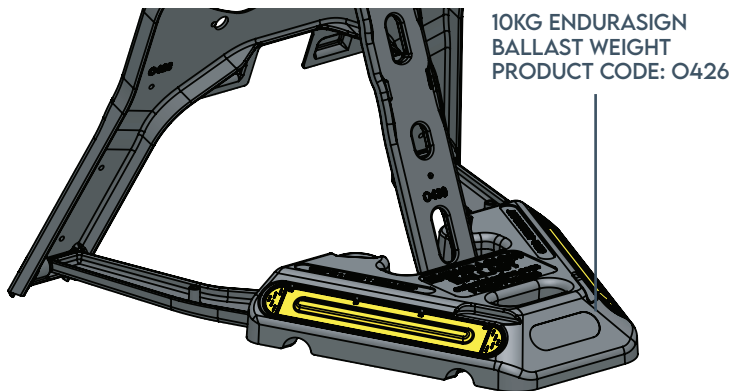
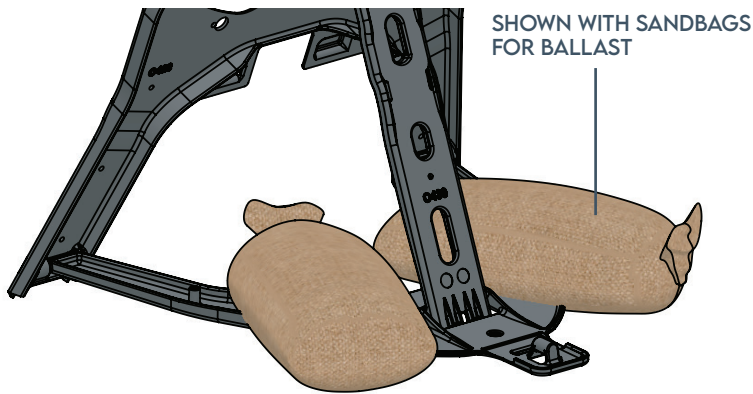

CODE COMPLIANCE

Wind classes are taken from BS 8442 (2006) Miscellaneous Road Traffic Signs and Devices – Requirements and Test Methods.

Wind tests conform to BS 8442 (2006) Annex B



For added stability, cable tie the EnduraBallast onto the EnduraSign QuickFit Frame as shown.

Ballast required for Windspeed Categories

Assembled Signface	C: 8.7m/s (19mph)		B: 17.6m/s (39mph)		A: 26.3m/s (58mph)	
	Sandbag Weight	EnduraSign Ballast	Sandbag Weight	EnduraSign Ballast	Sandbag Weight	EnduraSign Ballast
750mm Triangle	None	None	8kg	One	22kg	Three
600mm Square	None	None	7kg	One	21kg	Three
750mm Circle	None	None	5kg	One	17kg	Two
1050 x 750mm Rectangle	None	None	13kg	Two	36kg	Four
600 x 450mm Rectangle	None	None	4kg	One	13kg	Two
1050 x 450mm Rectangle	None	None	7kg	One	20kg	Two
750mm Triangle + Supplementary	None	None	9kg	One	26kg	Three





WIND DATA SCALE SPECIFICATIONS

WIND CLASSIFICATIONS FOR BS8442

Wind Class	Meters per second (m/s)	Mile per hour (mph)
Class A	26.3	59
Class B	17.6	39.6
Class C	8.7	19.6

CLASSIFICATION AND LABELLING OF UNITS

The manufacturer shall indicate the mass ballast to be added to each barrier assembly to resist a specified class of wind speed, depending upon the barrier configuration and the level of wind resistance chosen.

BEAUFORT SCALE, WIND FORCE OR GALE FORCE

Force 2	8-12mph	Gentle breeze, leaves and small twigs in constant motion, wind extends light flag
Force 3	13-18mph	Moderate breeze, raises duct loose paper, small branches are moved
Force 5	19-24mph	Fresh breeze, small trees in leaf begin to sway, crested wavelets form on inland water
Force 6	25-31mph	Strong breeze, large branches in motion, whistling heard in telegraph wires, umbrellas difficult
Force 7	32-38mph	Near gale, walking noticeably hampered
Force 8	39-46mph	Gale, branches break, walking very difficult
Force 9	47-54mph	Severe gale, slates blown off roofs
Force 10	55-63mph	Storm, trees up rooted





DURABILITY TESTING



DRIVE OVER TEST

Manufactured with a flexible material that won't crack, the Endurasign QuickFit Frame can endure being driven over by a HGV and remain intact and useable.

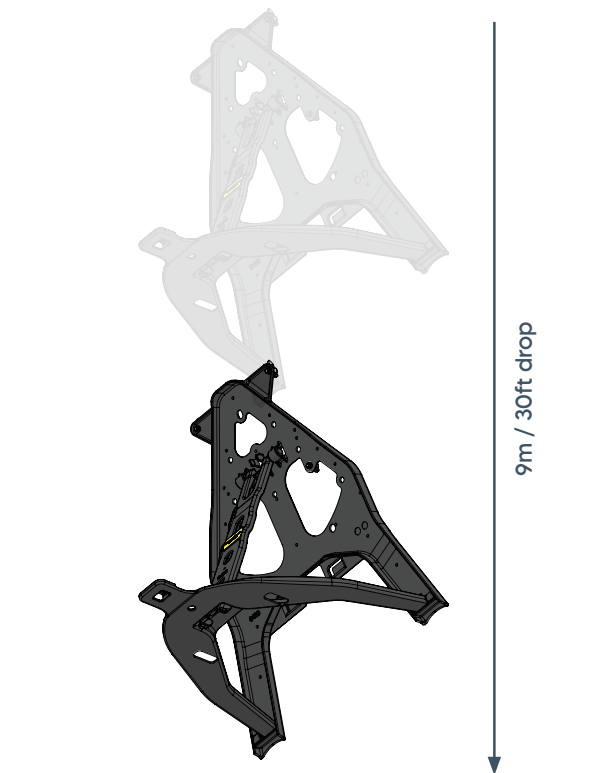

DROP TEST

The Endurasign QuickFit Frame is tested and proven to withstand a drop from 9m / 30ft high without sustaining any damage.



COLOUR AND CUSTOMISATION

THEFT PREVENTION AND INVENTORY MANAGEMENT WITH CORPORATE CUSTOMISATIONS

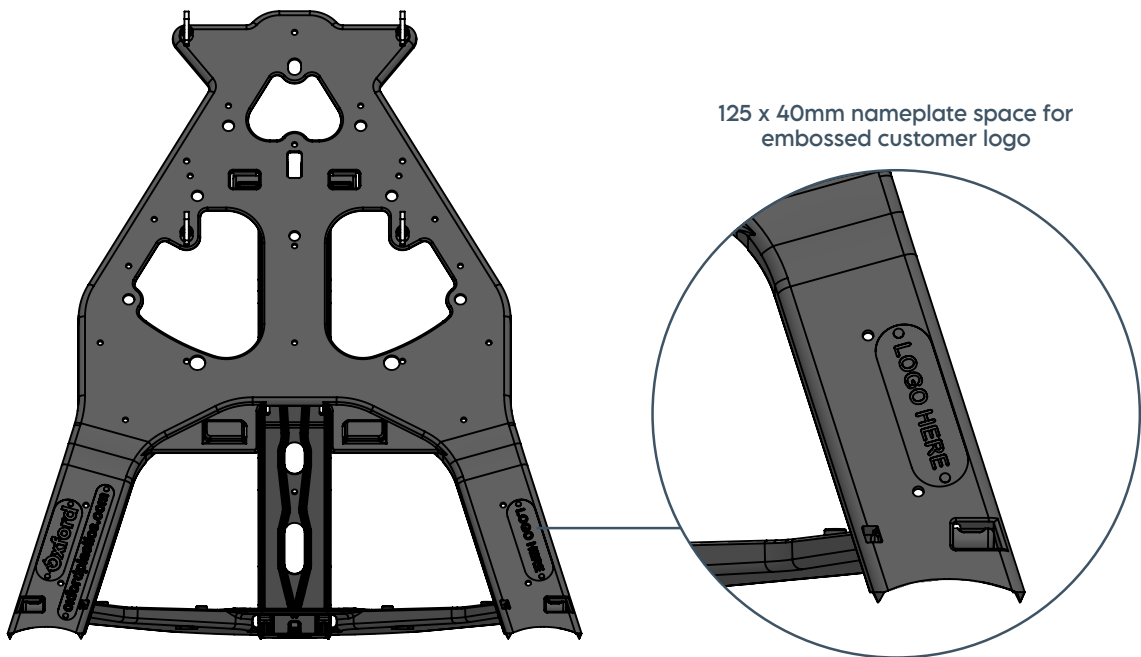

RAL coloured frames, MOQ 150

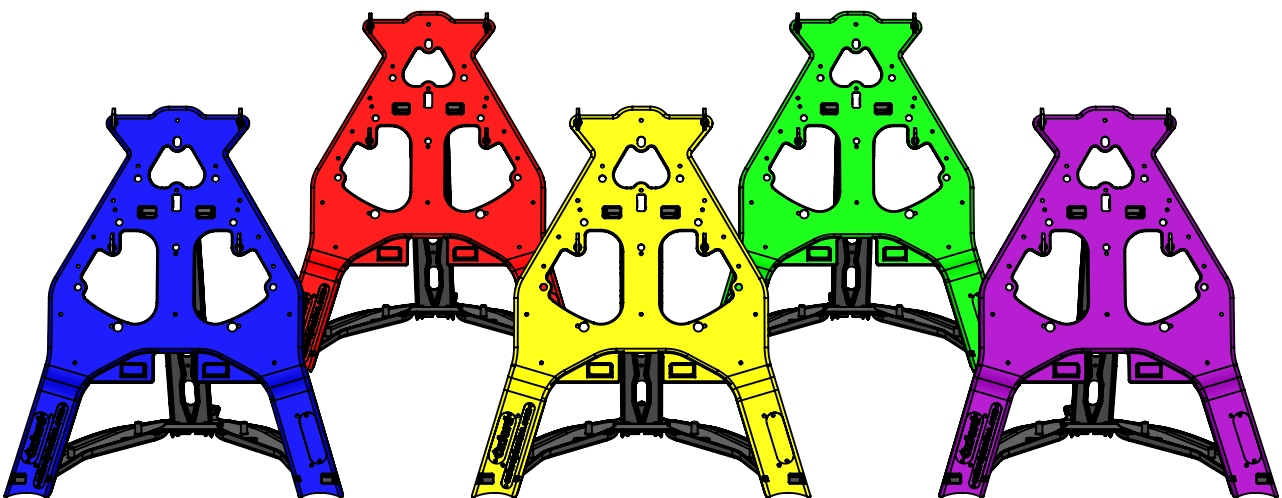



COMPACTNESS AND LIGHTNESS

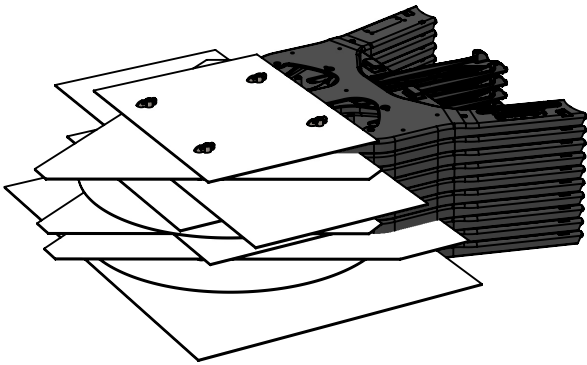

Endurasign QuickFit can be stacked with signfaces still attached.

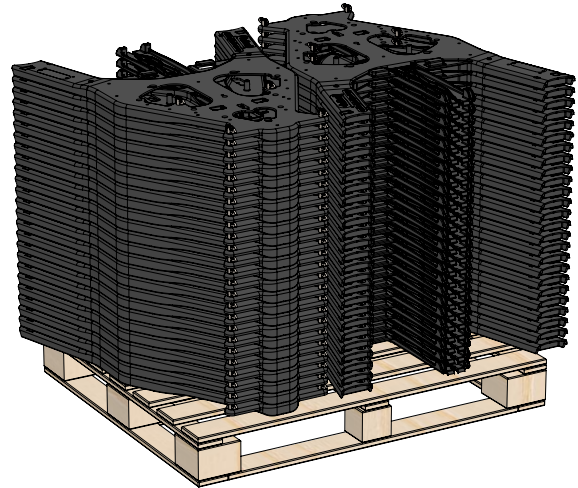

Fifty Endurasign QuickFit Frames stacked in two lots of twenty-five on a pallet.

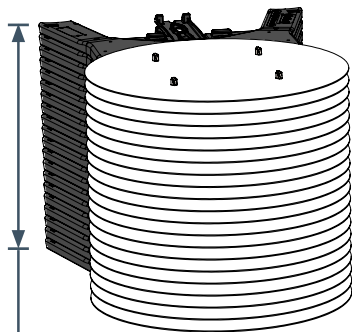

20x Endurasign QuickFits stacks 700mm high

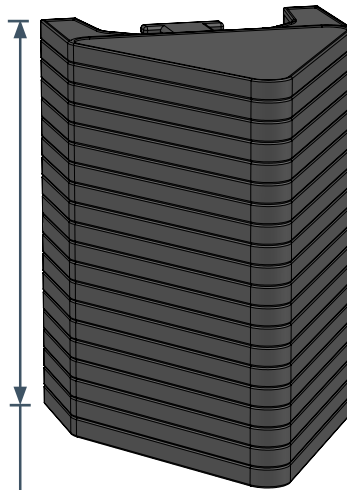

20x Alternative Plastic Signs stacks 1200mm high

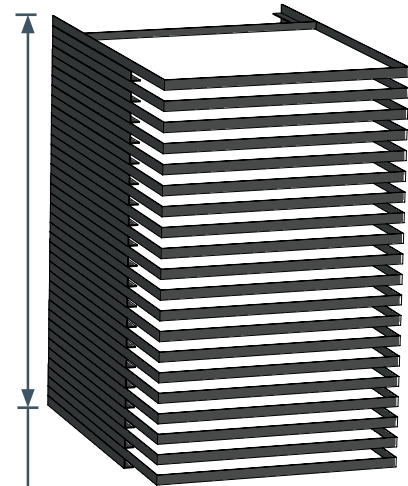

20x Metal Signs stacks 1240mm high

	EnduraSign QuickFit	Alternative Plastic Sign	Metal Sign
Triangle Sign Weight	4.3kg	6.8kg	6.35kg
Stacked Sign Height	35mm	60mm	62mm





SPARES AND MAINTENANCE

Parts can be disassembled, enabling elements to be replaced in the unlikely event of damage.

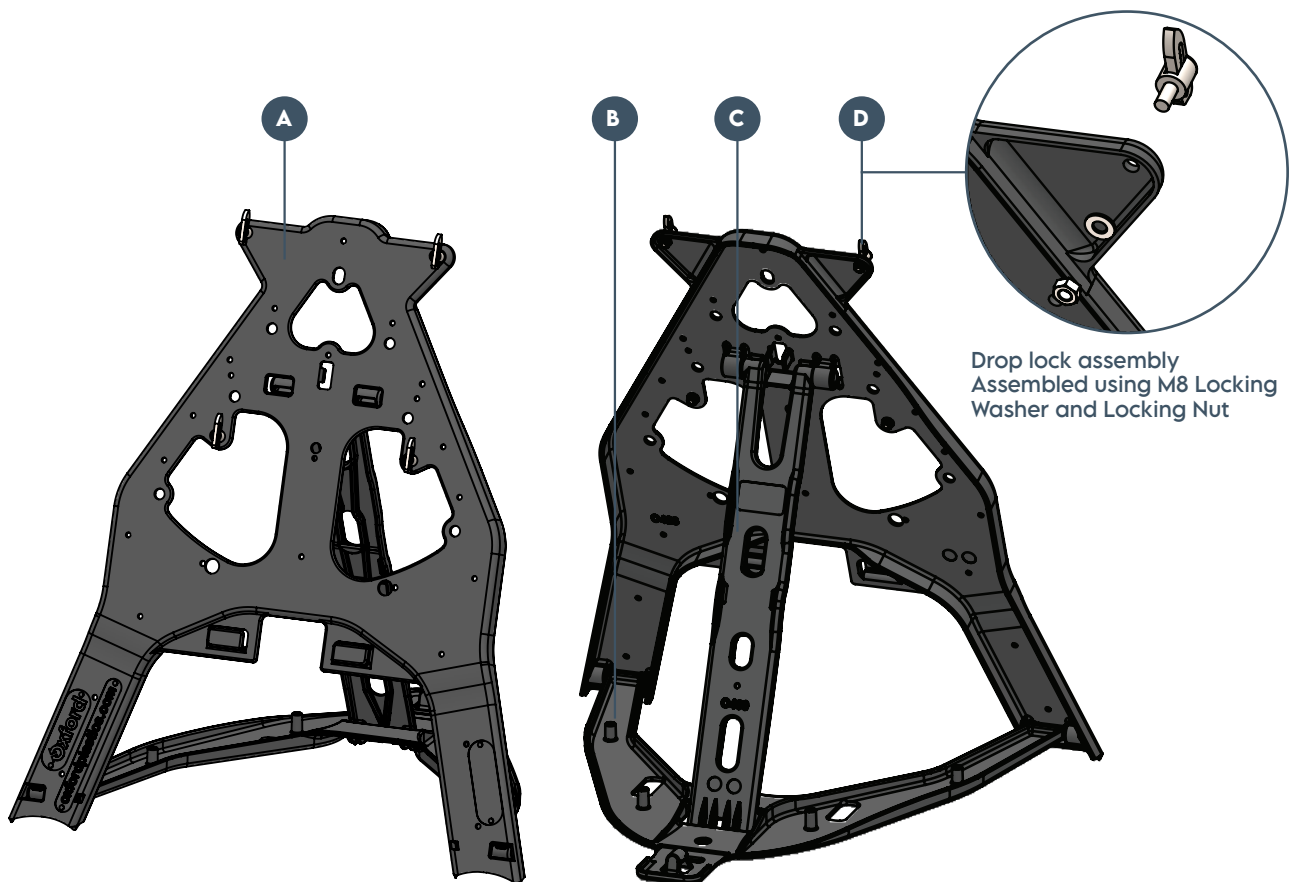

	Part Name	Material	Product code
A	Body	Black - Recycled plastic Custom colour - Virgin plastic	O428
B	Stay	Black - Recycled plastic	O429
C	Leg	Black - Recycled plastic	O430
D	Drop lock	Galvanised steel	O425





RECYCLABILITY

RECYCLABLE PRODUCTS

Made using recycled plastic materials

End of life products can be returned to Oxford Plastics for recycling.

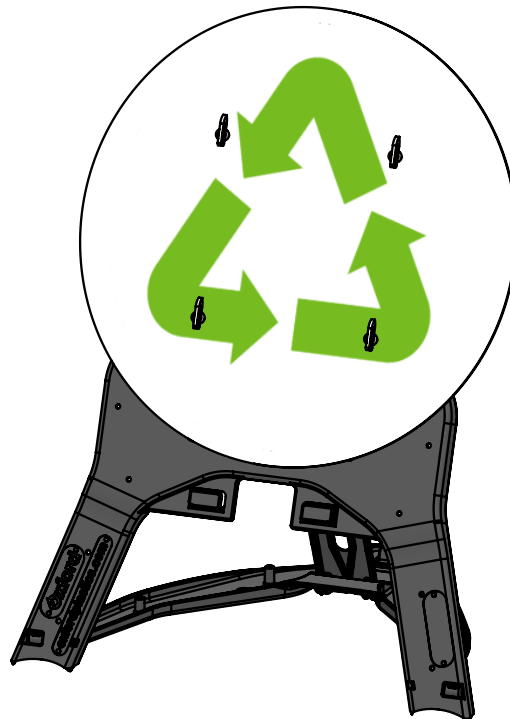

The EnduraSign Ballast, made of recycled PVC, can be re-ground at Oxford Plastics and used to make new products.

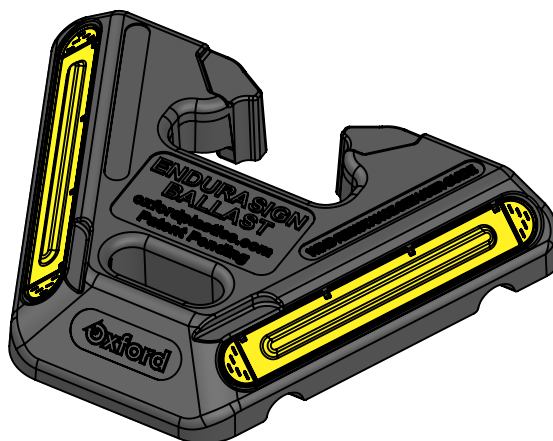

ASSOCIATED PRODUCTS

When setting up a street works site, other Oxford Plastics solutions can be used to ensure compliance is achieved. Browse our Chapter 8 solutions; including advanced barrier systems, trench covers, road plates, wheelchair ramps and street works signs.



**ADVANCED
BARRIER SYSTEMS**



**PORTABLE
GATE BARRIERS**



**GROUND
PROTECTION**



**WHEELCHAIR
RAMPS**



**TRENCH
COVERS**

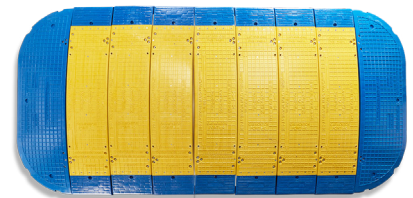

**ROAD
PLATES**



CONTACT INFORMATION

UK & R.O.W

Oxford Plastic Systems Ltd
Unit T2, Enstone Business Park
Enstone,
Chipping Norton
Oxfordshire
OX7 4NP
United Kingdom

sales@oxfordplastics.com
Tel: +44(0)1608 678888

USA

Oxford Plastic Systems LLC
1011 Centre Rd,
Suite 312,
Wilmington
DE
19805
USA

info@oxfordplasticsusa.com
1-800-567-9182

