



Oxford
WE'VE GOT IT COVERED

**WORKSITE
SAFETY
PRODUCTS**

2024



Contents

CONTENTS PAGE	3	TRAFFIC MANAGEMENT	34-39
INTRODUCTION	4-5	▶ ENDURASIGN QUICKFIT FRAME®	36
SUSTAINABILITY	6-7	▶ ENDURAFRAME™ 1500	37
INNOVATION	8-9	MATS AND GROUND PROTECTION	38-43
PRODUCT RANGE	10-52	▶ ENDURAMAT™ 2440	40
TRENCH COVERS AND ROAD PLATES	10-21	▶ ENDURAMAT™ 2400	41
▶ LOWPRO® TRENCH COVER GUIDE	12	▶ CLEARPATH® MAT	42
▶ LOWPRO® 100 NARROW TRENCH COVER	13	▶ ENDURAGRID™	43
▶ LOWPRO® 11/11 TRENCH COVER	14	FENCE FEET AND HEAVY BASES	44-52
▶ LOWPRO® 12/8 TRENCH COVER SYSTEM	15	▶ OXSTAND®	46
▶ LOWPRO® 15/10 TRENCH COVER SYSTEM	16	▶ TEMPORARY FENCE WEIGHT	47
▶ LOWPRO® 15/05 ROAD PLATE MKI	17	▶ OXBLOCK	48
▶ NEW LOWPRO® 15/05 ROAD PLATE	18	▶ SOLE BOARD	49
▶ LOWPRO® 23/05 ROAD PLATE	19	▶ SQUARE BASE	50
▶ 12/8 SAFE COVER	20	▶ OCTAGONAL BASE	51
▶ 16/12 SAFE COVER	21	▶ EURO BASE	52
WHEELCHAIR RAMPS	22-25	CONTACT US	
▶ SUPAGRIP® RAMP	24		
▶ ACCESSIBILITY IN STREET WORKS	25		
BARRIERS AND FENCING	26-33		
▶ AVALON® BARRIER	28		
▶ STRONGWALL®	29		
▶ DROPBLOCK	30		
▶ SAFEGATE®	31		
▶ OXFORDWALL®	32		
▶ FENCE PIN	33		



Solving problems for safer working.

Oxford
WE'VE GOT IT COVERED

Since 1985, Oxford Plastics has been dedicated to helping industrial workers do their jobs safely and efficiently.

Our award-winning ranges of intelligent, compliant, problem-solving products are creating safe working environments for people across a host of industries – including highways, utilities, events and streetworks; as well as the industrial, civil engineering and construction sectors.

We also collaborate closely with the Departments for Transport and industry leaders around the world, such as JAG, HAUC, NJUG and REMA, ADA and respected professors of Engineering. This ensures safety standards and product integrity are not only met, but consistently exceeded.

As the world changes, so do we. We're committed to creating even better solutions and delivering even better solutions always know that whatever challenges they face, we've got it covered.

Our Promise To Customers

We have introduced a service level agreement for our customers. Quotes will be returned to you within 4 hours of contacting Oxford Plastics. We're also now able to offer next-day delivery to our UK customers, where we have products in stock and where the location is appropriate.

Increased Production Capacity

We've also been working on shortening lead times and improving product availability, including our industry-leading LowPro Trench Cover and Road Plate range. Any enquiry, order, or question, we've got it covered.

Innovation

Innovation is at the heart of Oxford Plastics. We constantly invest in innovation and development of the products we provide to you. Not only to improve existing products but also to introduce new products, like the new LowPro 15/05 Road Plate.

We are bringing our first road plate into the present day. With an updated design consistent with the LowPro 23/05, the integration of the EasiLift Handles and all while remaining compatible with the previous generation LowPro 15/05.



What is a carbon footprint?

Pretty much everything we do and buy produces CO₂e.

A carbon footprint is the total amount of greenhouse gases produced directly and indirectly by any activity. Greenhouse gases are converted into a carbon dioxide equivalent (CO₂e), and are measured in tons (tCO₂e) or kilograms (kgCO₂e) of carbon dioxide equivalent.

How can you reduce your carbon footprint?

By taking sustainable actions and working within the circular economy. 4 tangible steps all businesses should take to reduce emissions, repair equipment, pass on, sell or hire out items they don't need for reuse, and recycle materials at end of life.

The circular economy

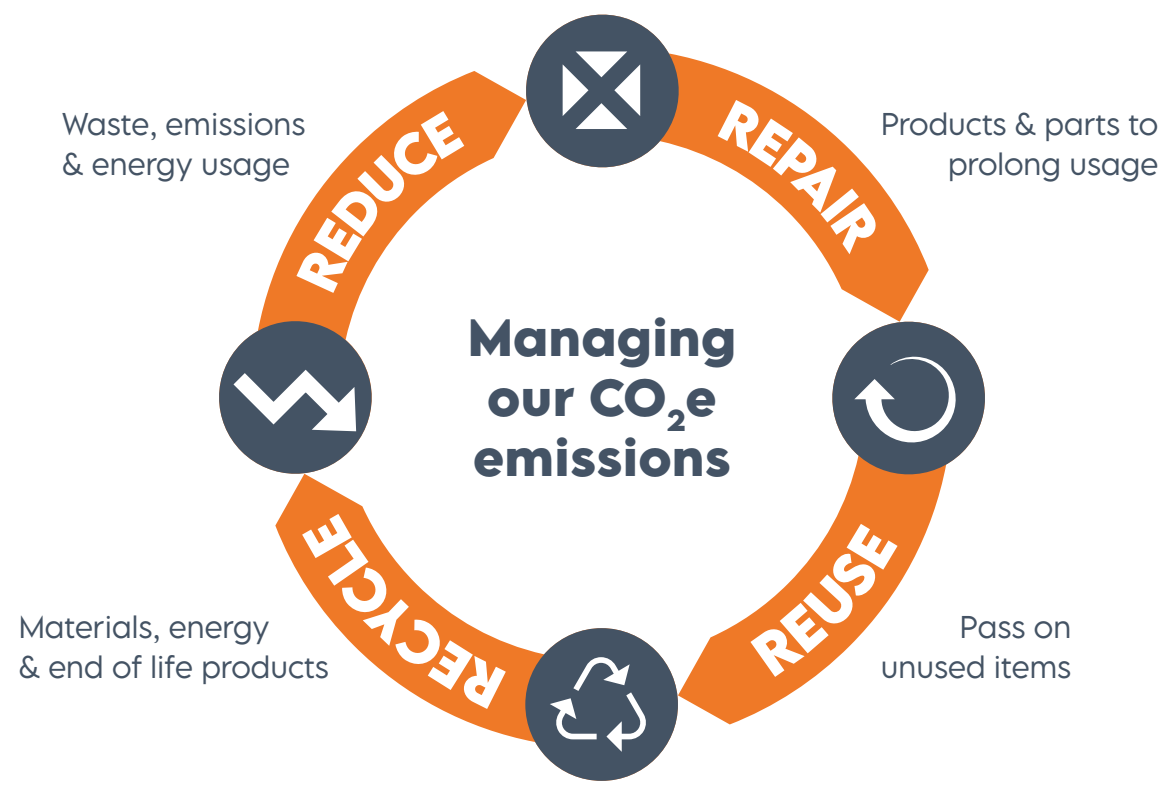

Our commitment to sustainability

At Oxford Plastics, we believe in sustainable products. Since 2021, we have brought new carbon measurements into our business.

1
Designing out waste and pollution

2
Keeping products and materials in use

3
Manufacturing innovative site safety equipment

Our credentials

Site carbon footprint: 2,912t

Product embodied carbon footprint: Shows the embodied footprint of our products

Reduce product lifecycle carbon footprint: **REPAIRABLE** Making products that reduce our customer's carbon footprint

Carbon footprint comparisons: We create product comparison studies so our customers can make low CO₂ choices

The LowPro 15/10 Trench Cover is the strongest of its kind. 2.5 times stronger than the next alternative.

LowPro 23/05 Road Plates can save up to 79% of CO₂e over their lifecycle, compared to steel plates.

The Avalon Barrier has 30% less kgCO₂e compared to single piece, non-repairable barriers.

Latest innovations

New LowPro® 15/05 Road Plate

The next generation composite trench cover: New LowPro 15/05 Road Plate. Building on the solid product features of the LowPro 15/05 MKI and the LowPro 23/05 Road Plates, the new LowPro 15/05 completes our market-leading range. This new Road Plate is still manually installed and suited for vehicles up to 44 tonnes over a 700mm trench.

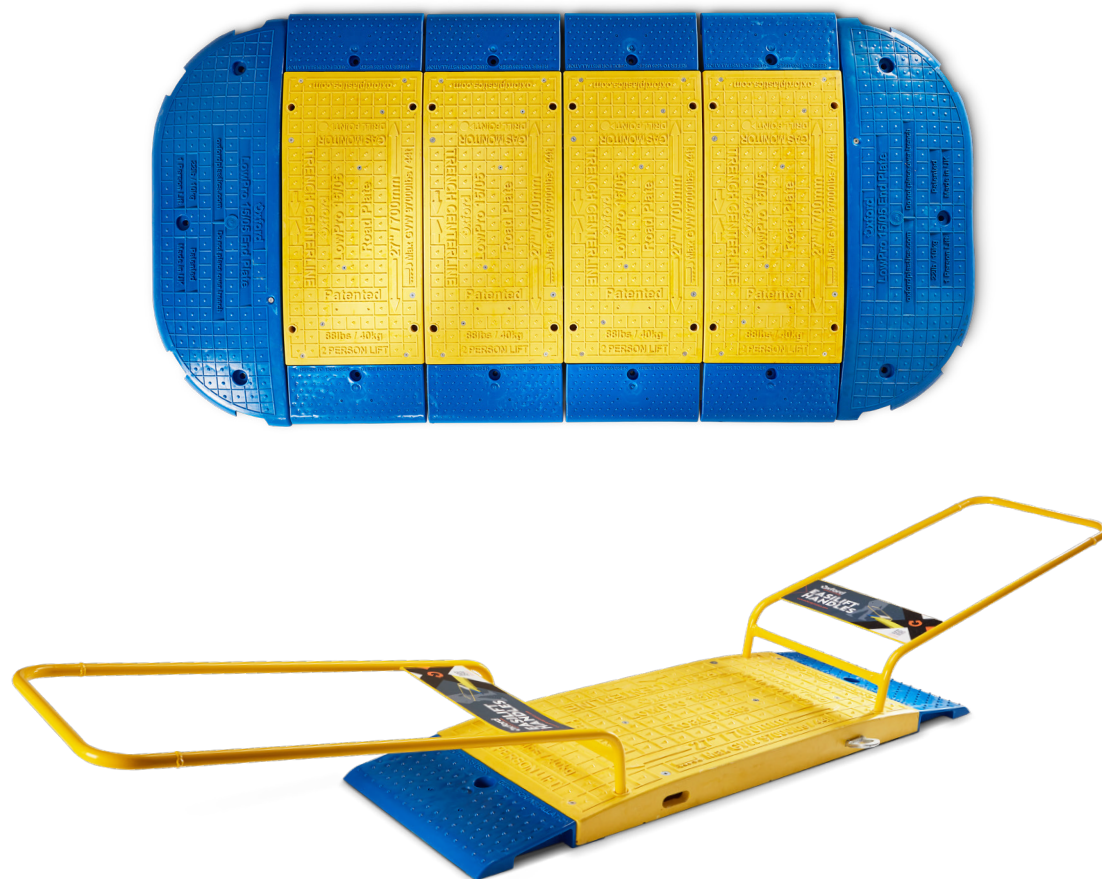

This improved Road Plate is designed for stable stacking on a pallet, featuring a new flat-top surface.

Best of all, the new LowPro 15/05 Road Plate is compatible with the LowPro 15/05 MKI, meaning that users can use their existing stock together with the latest and improved LowPro 15/05.

Added benefits for the new LowPro 15/05 Road Plate:

- ▶ Flat-top surface for better stability on the pallet and when in transit
- ▶ Easy-to-follow instructions are moulded into the surface
- ▶ Now compatible with the EasiLift handles for easy installation

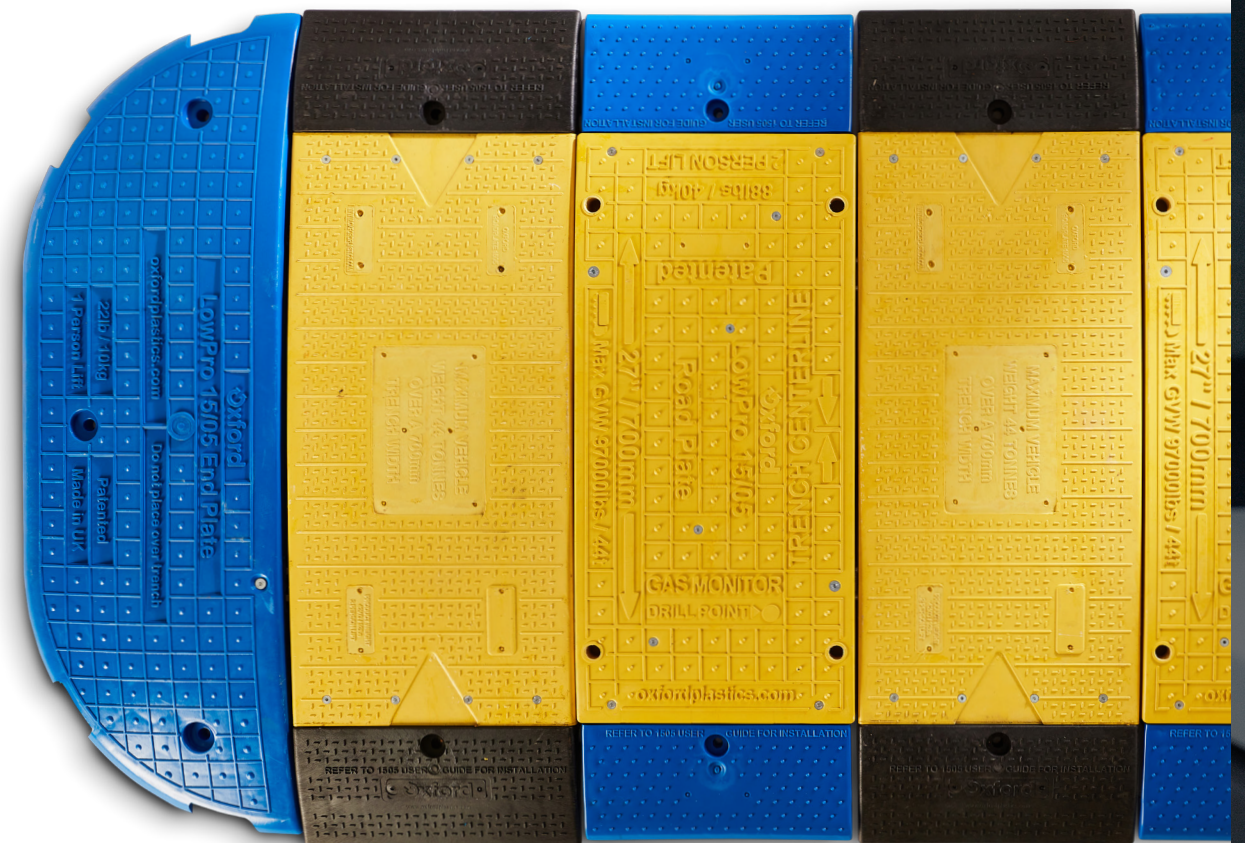



Trench Covers and Road Plates

Oxford Plastics has spent over 20 years refining the material composition, technology and manufacturing processes of our flagship LowPro Trench Covers and Road Plates range.

Today, we offer the most comprehensive range of composite covers in the world, which can be used in a variety of scenarios from footways to carriageways in street works and on construction sites.

The LowPro range is designed to replace steel plates and wooden boards. Light enough to be installed by hand, the LowPro range makes covering excavations quick, quiet and easy. Tested to ensure a 2:1 safety factor, the LowPro range is built to last, with little to no maintenance costs.

GUARANTEED
MAXIMUM LOAD WEIGHT UP TO

44
TONNES
OVER 1200MM TRENCH

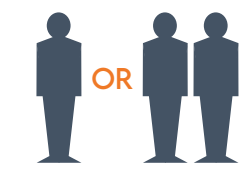

1 OR 2 PERSON INSTALLATION

ROAD PLATE PATENTED
DROP-PIN SECURITY



TESTED TO ENSURE A

2:1
SAFETY FACTOR

RAMPED LOWPRO EDGES
FOR SAFE ACCESS











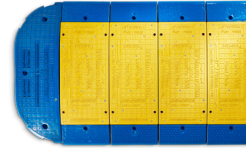

HAUC
UK
HIGHWAY AUTHORITIES & UTILITIES COMMITTEE
FULLY COMPLIANT

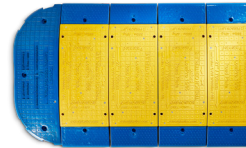
LOWPRO® TRENCH COVER GUIDE

COMPOSITE TRENCH COVERS CAN BE INSTALLED IN THE FOLLOWING SCENARIOS.

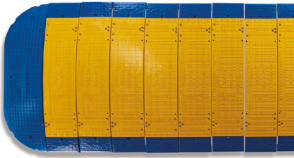
- ▶ A Site Safety Risk Assessment must be carried out before installation, only install on compacted surfaces such as concrete or asphalt. Always place the trench cover centrally over the excavation.
- ▶ In some instances, road plates and trench covers must be bolted for safety, refer to the installation guide for more details.
- ▶ Trench covers have a maximum width allowance.
- ▶ Trench covers can be linked together to safely cover any length of excavation.
- ▶ The LowPro range is HAUC Compliant.
- ▶ LowPro 15/05 and LowPro 23/05 are HS20-44 load rated.
- ▶ Trench covers must be installed centrally over the trench.

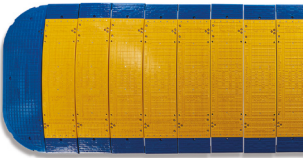
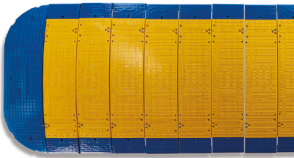
MAXIMUM TRENCH WIDTH	WHAT TYPE OF TRAFFIC WILL CROSS THE TRENCH?		
	FOOTWAY 400KG / 880LBS	DRIVEWAY 3.5T / 7715LBS VEHICLE	ROADWAY 44T / 97000LBS VEHICLE
100MM 4"	 LowPro 100	 LowPro 100	 LowPro 15/05
700MM 2FT	 LowPro 12/8	 LowPro 15/10	 LowPro 15/05
	 LowPro 11/11		
900MM 3FT	 LowPro 15/10	 LowPro 15/10	 LowPro 23/05
1200MM 4FT	 LowPro 15/10	 LowPro 23/05	 LowPro 23/05

LOWPRO® 100 NARROW TRENCH COVER

TRENCH COVER

Developed for Project Gigabit, the LowPro Narrow Trench Cover is ideal for fibre-optic cable installations. It is suitable for 75mm-100mm wide trenches. The recycled plastic material grips the asphalt to minimise movement and provide a stable surface for pedestrians and vehicles. Available in 1m sections, the LowPro 100 is supplied with fixings to bolt pieces together.

PRODUCT RANGE



LOWPRO® 100 NARROW TRENCH COVER

Usage Benefits

- ▶ Designed for fibre optic cable installations & maintenance
- ▶ Suitable for Narrow-Trenching: 75mm-100mm excavations
- ▶ Low profile, sits flat against the ground
- ▶ Bends 30 degrees
- ▶ Suitable for pedestrian traffic and vehicles
- ▶ 1m sections can securely bolt together
- ▶ Made using recycled plastic and is recyclable
- ▶ Highly slip-resistant in wet & dry conditions
- ▶ Hivis inserts for safety day and night
- ▶ Use the LowPro 11/11 over T-Junctions
- ▶ Comes with nyloc fixings

	LOWPRO® 100 NARROW TRENCH COVER	
	20MM DEPTH	
Product No.	O762	
Width	250mm	
Length	1065mm	
Height	33mm	
Weight	3.2kg	
Quantity / Pallet	100	
Colour	Black & Yellow	

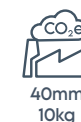
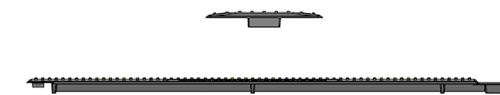

40mm
10kg

COMPLIANCE CODES BS 7976-2+A1:2013

LOWPRO® 11/11 TRENCH COVER

TRENCH COVER

Pedestrian board with patented LowPro Edge technology, suitable for the distributed load of a 1.6 tonnes vehicle over a 700mm trench.

PRODUCT RANGE



LOWPRO® 11/11 TRENCH COVER

Usage Benefits

- ▶ Extremely compact and flat making it easy to transport & store
- ▶ Can be easily lifted and installed by 1 person
- ▶ Safely cover holes and trenches up to 700mm
- ▶ Create temporary and semi-permanent footways and trench cover
- ▶ Not for use in roadway
- ▶ Enquire about minimum order quantities for customisations
- ▶ Hi-vis and anti-trip trench cover provides a safe passageway for pedestrians and vehicles up to 1.6 tonnes
- ▶ Trench covers must be installed centrally over the trench
- ▶ Reduce CO₂ emissions with lighter transport compared to steel plates

	LOWPRO® 11/11 TRENCH COVER
Product No.	O825
Width	1125mm
Length	1125mm
Height	17mm
Weight	24kg
Quantity / Pallet	30
Colour	Yellow & Black

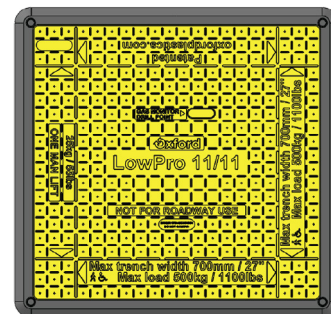

57kg



LOWPRO® 12/8 TRENCH COVER SYSTEM

TRENCH COVER SYSTEM

The LowPro 12/8 Trench Cover is a versatile trench cover that is suitable for pedestrians and 1.6 tonnes vehicles over a 700mm trench.

PRODUCT RANGE

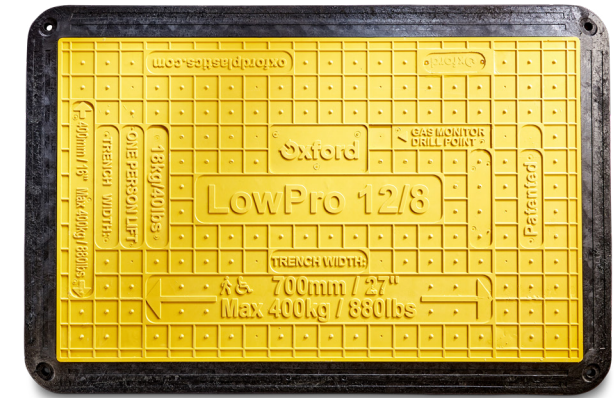

LOWPRO® 12/8 TRENCH COVER

Usage Benefits

- ▶ Can be easily installed, transported and stored by 1 person
- ▶ Safely cover holes and trenches up to 700mm
- ▶ Hi-vis and anti-trip trench covers create a safe passageway for pedestrians, wheelchairs and vehicles
- ▶ Not for use in roadway
- ▶ Prevent drifting using our patented LowPro Edge technology and Infill connectors strips
- ▶ To support pedestrians, vehicles and cargo up to 1.6 tonnes
- ▶ To be configured individually and as part of a larger system including infill strips
- ▶ Patented LowPro Edges are moulded around the whole board, creating a durable protective barrier for the trench cover
- ▶ Enquire about minimum order quantities for customisations
- ▶ Trench covers must be installed centrally over the trench
- ▶ Reduce CO₂ emissions with lighter transport compared to steel plates

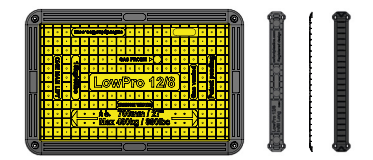

	LOWPRO® 12/8		
	TRENCH COVER	INFILL SHORT	INFILL LONG
Product No.	O362	O383	O364
Width	800mm	150mm	150mm
Length	1200mm	800mm	1200mm
Height	28mm	26mm	26mm
Weight	17kg	1.5kg	2kg
Quantity / Pallet	30	5/100	5/100
Colour	Yellow & Black	Black	Black



Cover
126kg



Infil Short
4kg



Infil Long
6kg

LOWPRO® 15/10 TRENCH COVER SYSTEM

TRENCH COVER SYSTEM

The LowPro 15/10 Trench Cover is a modular system of linking trench covers, comprising the trench cover, infill strips and ramps.

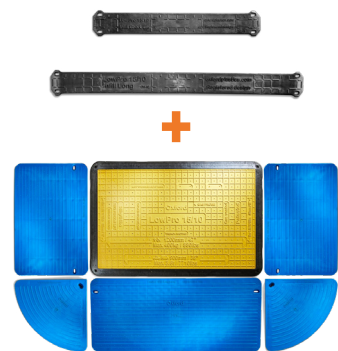

PRODUCT RANGE



LOWPRO® 15/10 TRENCH COVER

Usage Benefits

- ▶ Can be easily installed, transported and stored by 2 people
- ▶ Safely cover holes and trenches up to 900mm
- ▶ Patented LowPro Edges are moulded around the whole board, creating a durable protective barrier for the trench cover
- ▶ Prevent drifting using our patented LowPro Edge technology and Infill connector strips
- ▶ To support vehicles up to 3.5 tonnes
- ▶ Hi-vis and anti-trip trench covers create a safe passageway for pedestrians, wheelchairs and vehicles
- ▶ Enable access for residents to their homes
- ▶ Enquire about minimum order quantities for customisations
- ▶ Trench covers must be installed centrally over the trench
- ▶ Ramp attachments in long, short and corner sizes create a smooth 1:12 gradient for vehicles and pedestrians.

	LOWPRO® 15/10		
	TRENCH COVER	INFILL SHORT	INFILL LONG
Product No.	0815	0375	0840
Width	1000mm	150mm	150mm
Length	1500mm	1000mm	1500mm
Height	37mm	35mm	35mm
Weight	38kg	2kg	2.3kg
Quantity / Pallet	20	5/100	5/100
Colour	Yellow & Black	Black	Black

	LONG RAMP	SHORT RAMP	CORNER RAMP	STILLAGE
	Product No.	0774	0798	0775
Width	42mm	42mm	42mm	1200mm
Length	645mm	645mm	577mm	1200mm
Height	1490mm	990mm	577mm	1500mm
Weight	9kg	8.75kg	2.45kg	60kg
Quantity / Pallet	50	50	100	1
Colour	Blue	Blue	Blue	Silver

LOWPRO® 15/05 ROAD PLATE MKI

TRENCH COVER

The LowPro 15/05 Road Plate MKI is a modular system of singular linking units. This road plate trench cover is suitable for 44 tonnes vehicles over a 700mm trench.

PRODUCT RANGE

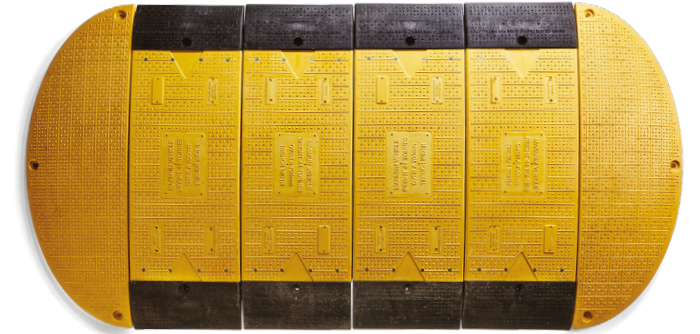

LOWPRO® 15/05 ROAD PLATE MKI

Usage Benefits

- ▶ Can be easily transported and stored
- ▶ Lifted and installed by 2 persons without a crane or heavy-lifting equipment
- ▶ Safely cover holes and trenches up to 700mm
- ▶ Create temporary and semi-permanent road covers
- ▶ To support vehicles up to 44 tonnes
- ▶ Clearly defined thoroughfares to safely direct road traffic and vehicles
- ▶ Maintain quality and performance with spare parts, if necessary
- ▶ To be configured individually and as part of a larger system
- ▶ Trench covers must be installed centrally over the trench
- ▶ Reduce CO₂ emissions with lighter transport compared to steel plates

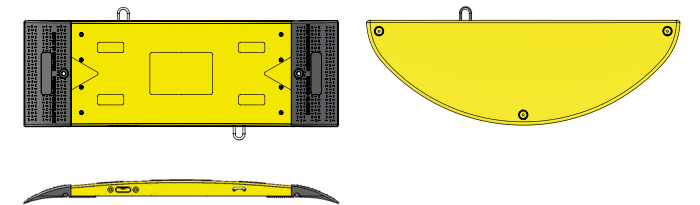

	LOWPRO® 15/05 ROAD PLATE MKI	
	INNER	END
Product No.	0830	0814
Width	500mm	500mm
Length	1500mm	1500mm
Height	75mm	75mm
Weight	42kg	23kg
Quantity / Pallet	20	20
Colour	Yellow & Black	Yellow



NEW LOWPRO® 15/05 ROAD PLATE

TRENCH COVER

The new LowPro 15/05 Road Plate is a modular system of singular linking units. This road plate trench cover is suitable for 44 tonnes vehicles over a 700mm trench.

PRODUCT RANGE

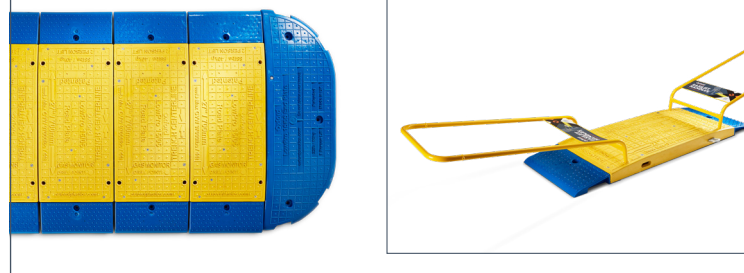

NEW LOWPRO® 15/05 ROAD PLATE

Usage Benefits

- ▶ Compatible with LowPro 15/05 MKI
- ▶ Safely cover holes and trenches up to 700mm
- ▶ To support vehicles up to 44 tonnes
- ▶ Can be easily transported and stored by 2 people using Easilift handles or handhold points
- ▶ Flat top for stable stacking
- ▶ Create temporary and semi-permanent road covers
- ▶ Clearly defined thoroughfares to safely direct road traffic and vehicles
- ▶ Maintain quality and performance with spare parts, if necessary
- ▶ Trench covers must be installed centrally over the trench
- ▶ Reduce CO₂ emissions with lighter transport vehicles compared to steel plates

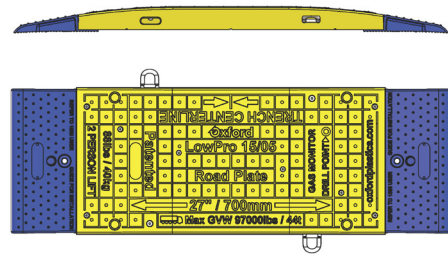

	NEW LOWPRO 15/05 ROAD PLATE		
	INNER	END	EASILIFT HANDLES
Product No.	O900	O903	O730
Width	500mm	500mm	457mm
Length	1500mm	1500mm	925mm
Height	75mm	75mm	196mm
Weight	40kg	10kg	3kg
Quantity / Pallet	20	20	20
Colour	Yellow & Blue	Blue	Yellow

NEW FOR SPRING, 2024



COMPLIANCE CODES HAUC 2018/01 Road Plate

LOWPRO® 23/05 ROAD PLATE

TRENCH COVER

The LowPro 23/05 Road Plate is a modular system of singular linking units, this road plate trench cover is suitable for 44 tonnes vehicles over a 1200mm trench.

PRODUCT RANGE

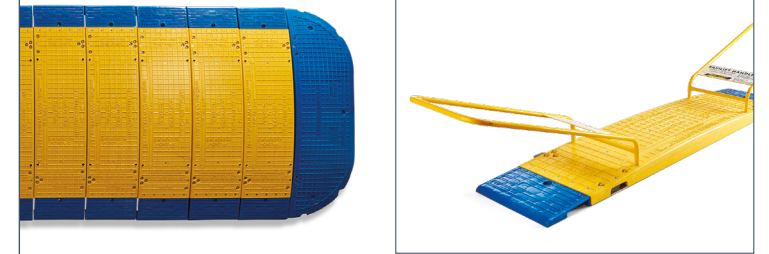

LOWPRO® 23/05 ROAD PLATE

Usage Benefits

- ▶ Can be easily transported and stored in the stillage
- ▶ Lifted and installed by 2 persons using Easilift Handles, without a crane or heavy lifting equipment
- ▶ Safely cover holes and trenches up to 1200mm wide
- ▶ Create temporary and semi-permanent road covers
- ▶ Clearly defined thoroughfares to safely direct road traffic and vehicles
- ▶ To support vehicles up to 44 tonnes
- ▶ Maintain quality and performance with spare parts, if necessary
- ▶ To be configured as part of a larger system, use multiple road plate inners to cover any length of trench
- ▶ Trench covers must be installed centrally over the trench
- ▶ 79% reduction in CO₂e compared to steel plates

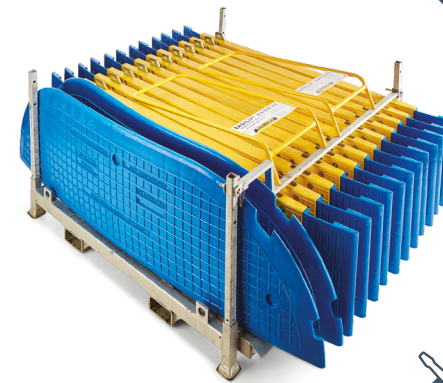
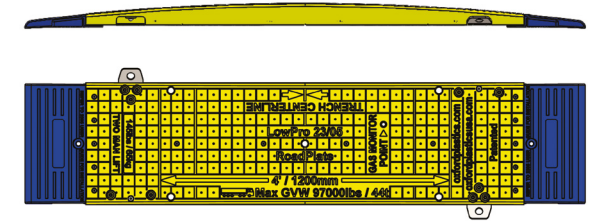

COMPLIANCE CODES HAUC 2018/01 Road Plate

	LOWPRO® 23/05 ROAD PLATE			EASILIFT HANDLES
	INNER	OUTER	STILLAGE	
Product No.	0839	0726	0732	0730
Width	500mm	700mm	1613mm	457mm
Length	2300mm	2300mm	1779mm	925mm
Height	85mm	85mm	908mm	196mm
Weight	65kg	27kg	190kg	10kg
Weight when filled			1030kg	
Quantity / Pallet	16	10	1	20
Colour	Yellow & Blue	Blue	Silver	Yellow

12/8 SAFE COVER

TRENCH COVER

The 12/8 Safe Cover is a versatile, rigid and lightweight trench cover that is suitable for pedestrians and 2 tonnes vehicles over a 700mm trench.

PRODUCT RANGE

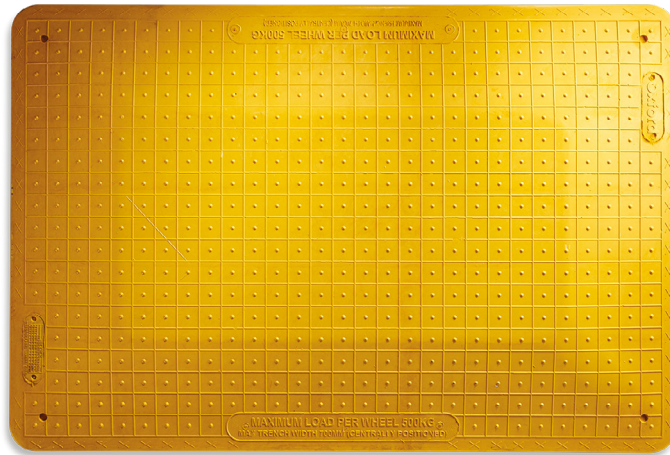

12/8 SAFE COVER

Usage Benefits

- ▶ Can be easily installed, transported and stored manually
- ▶ Safely cover holes and trenches up to 700mm
- ▶ Create temporary and semi-permanent trench covers quickly and easily, by bolting the cover to the ground for stability
- ▶ Create clearly defined thoroughfares to safely direct foot traffic and vehicles
- ▶ Adapt and customise cover with corporate branding and colours
- ▶ To support pedestrians and vehicles up to 2 tonnes
- ▶ Trench covers must be installed centrally over the trench

	12/8 SAFE COVER
Product No.	O307
Width	800mm
Length	1200mm
Height	30mm
Weight	13kg
Quantity / Pallet	30
Colour	Yellow

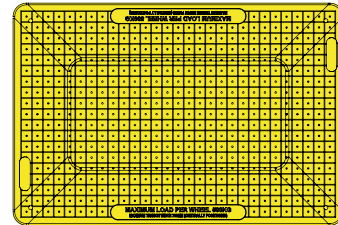

16/12 SAFE COVER

TRENCH COVER

The 16/12 Safe Cover is a strong and secure trench cover that is suitable for pedestrians and 3.5 tonnes vehicles over a 900mm trench.

PRODUCT RANGE

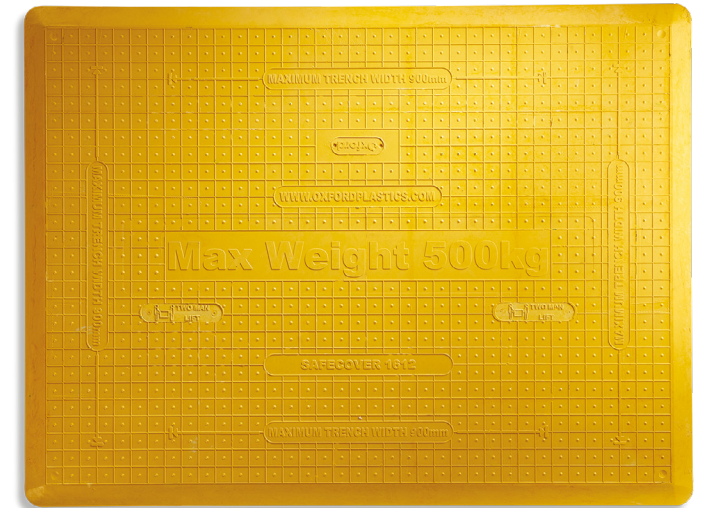

16/12 SAFE COVER

Usage Benefits

- ▶ Can be easily installed, transported and stored manually
- ▶ Safely cover holes and trenches up to 900mm
- ▶ Create temporary and semi-permanent trench covers quickly and easily, by bolting the cover to the ground for stability
- ▶ Create clearly defined thoroughfares to safely direct foot traffic and vehicles
- ▶ Adapt and customise cover with corporate branding and colours
- ▶ To support pedestrians and vehicles up to 3.5 tonnes
- ▶ Trench covers must be installed centrally over the trench

	16/12 SAFE COVER
Product No.	O820
Width	1200mm
Length	1600mm
Height	26mm
Weight	33kg
Quantity / Pallet	25
Colour	Yellow

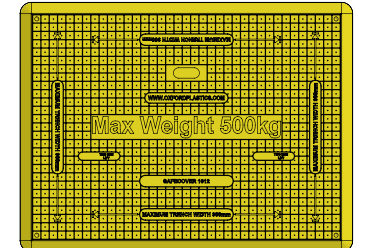



Wheelchair Ramps

Designed for street works where pedestrians are diverted from the footway into the roadway. Tested with UK disability groups using mobility scooters or wheelchairs and the partially sighted.

Highly slip resistant in wet and dry conditions, our Wheelchair Ramps are moulded with a durable anti-slip surface.

The SupaGrip Ramp uses our patented LowPro anti-slide technology, which grips the pavement for added stability.

**SLIP RESISTANT
IN WET & DRY**



1 PERSON INSTALLATION

HIGH VISIBILITY



**1:5
GRADIENT
AT 60MM KERB**

SUPAGRIP® RAMP

WHEELCHAIR RAMP

The SupaGrip Ramp is an anti-slide wheelchair ramp and pedestrian kerb ramp, designed for temporary roadworks access.

PRODUCT RANGE



SUPAGRIP® RAMP

Usage Benefits

- ▶ LowPro edges sit securely on the pavement without the need for pinning
- ▶ Can be easily transported and stored
- ▶ Can be easily lifted and installed by 1 person
- ▶ Can be safely used on kerbs between 60mm and 160mm
- ▶ Create temporary and semi-permanent kerb ramps
- ▶ Spare parts available, if necessary, to maintain the life of your wheelchair ramp
- ▶ Clearly defined thoroughfares to safely direct pedestrian traffic and mobility vehicles
- ▶ To support mobility vehicles and foot traffic up to 350kg
- ▶ Fully recyclable

	SUPAGRIP® RAMP
Product No.	O836
Width	1280mm
Length	760mm
Height	110mm
Weight	10kg
Quantity / Pallet	30
Colour	Yellow & Black

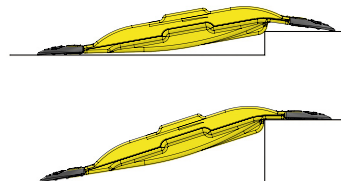
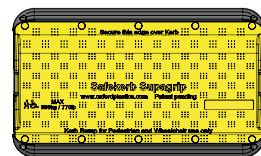

COMPLIANCE CODES HAUC 2018/01 Wheelchair Ramp, Safety at Street Works and Road Works (Red Book)

ACCESSIBILITY IN STREET WORKS

Street works are a necessary part of maintaining road infrastructure, pedestrian safety and the modernisation of our environment. However, this often poses its challenges to pedestrian accessibility – especially for those with a disability that affects their mobility.

That's why, here at Oxford Plastics, not only do we provide the relevant equipment to ensure that pedestrian safety is maintained at all times during street works, but also the

capability to cater for everyone – providing an all-inclusive way of working. We comply to the Disability Discrimination Act 1995 – meaning that our Chapter 8 street works products are applicable to those who have a disability, and can be used and installed in a way that caters specifically to those who have reduced mobility. This isn't always just wheelchair users, either – it could refer to the elderly, parents with prams and pedestrians who need to use a stick or a guide-dog.

It's also important to consider the hidden disabilities that people may be facing –



such as autism, dementia or learning disabilities. Although this may not directly hinder people's mobility, the impact of street works accessibility may be confusing for people – which again, shows why it's so important that the correct safety measures are implemented.

This is why Oxford Plastics works with the UK's main utility providers, street works contractors, local councils and disability groups to design products that make a difference.

ACCESSIBILITY PRODUCTS FROM OXFORD PLASTICS

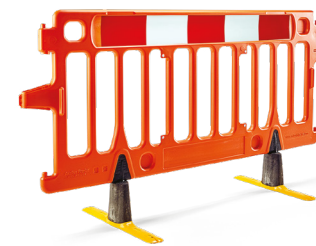

AVALON® CHAPTER 8 BARRIER WITH CLEARPATH EXTRA FEET

The only 100% anti-trip street works barrier, maximises the space for pedestrians on diverted walkways



LOWPRO® TRENCH COVER INFILLS & RAMPS

The only trench cover system with a smooth 1:12 gradient, designed for wheelchair users and cyclists to easily navigate street works



SUPAGRIP® WHEELCHAIR RAMP

The only wheelchair ramp with LowPro edges that grip the kerb and the asphalt, making it quick and easy for this DDA compliant ramp to be installed



Barriers and Fencing

Oxford Plastics manufacture a wide range of barrier and fencing solutions for street works, construction sites and facilities management.

Our Chapter 8 street works barrier range is used by businesses around the world to provide safe spaces for the workforce and the public. This includes 1m high pedestrian barriers, and 2m high fences for deep excavations and site protection. Featuring patented anti-tamper locking systems, pedestrian barriers are lightweight and are designed to be carried and installed by 1 person. Complete with high-quality British Standard reflective.

We also manufacture ballasting solutions made from recycled PVC, which replace unreliable sandbags.

HIGH WIND



RESISTANCE

REPAIRABLE



BRITISH
STANDARD



REFLECTIVE

CUSTOMISABLE



AVALON® BARRIER

PEDESTRIAN BARRIER

The Avalon is our most versatile and popular safety barrier. It is compliant with street works regulations and suitable for a wide range of indoor and outdoor pedestrian applications. Common uses include construction, excavation, street works, events and utilities sites.

PRODUCT RANGE



AVALON® BARRIER

Usage Benefits

- ▶ Adaptable to the work site's requirements with 2 feet options: ClearPath Extra which is 100% antitrip or standard.
- ▶ Can be easily transported and stored
- ▶ Clearly defined access in high traffic area
- ▶ Ensures physical distance measures
- ▶ Patented tamper-proof locking system to protect site staff and pedestrians against risk factors
- ▶ Keep a secure semi-permanent perimeter with our ballasting options, offering wind resistance up to Cat B
- ▶ Maintain quality and performance with spare parts, if necessary
- ▶ Enquire about minimum order quantities for customisations
- ▶ Able to be returned to Oxford Plastics to be fully recycled

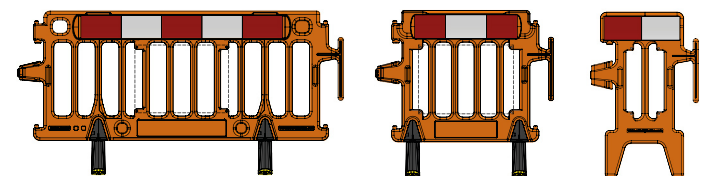

	AVALON® BARRIER		
	2M	1M	500MM
Product No.	O635	O634	O646
Width	40mm	40mm	40mm
Length	2005mm	1000mm	655mm
Height	1000mm	1000mm	1000mm
Weight	11kg	8.5kg	1.8kg
Quantity / Pallet	50	25	100
Colour	Orange	Orange	Orange



- Standard Foot 28kg
- ClearPath Extra Foot 26kg
- Repairable

STRONGWALL®

PEDESTRIAN BARRIER & FENCING

A robust plastic safety barrier which is used during building work or construction to ensure maximum safety to both members of the public and site workers.

PRODUCT RANGE



STRONGWALL®

Usage Benefits

- ▶ Create a highly stable barrier or fenced perimeter to combat high volumes of traffic even in hot weather conditions, with no additional ballast
- ▶ A heavy duty, durable component used for easy and effective installation
- ▶ A compact ballast option that can be easily stored and transported
- ▶ Keep worksites secure with 2m tall anti-climb fencing
- ▶ Enquire about minimum order quantities for customisations
- ▶ Be confident that your fence line will stay in tact with connections which are moulded to the barrier
- ▶ Non-conductive plastic to keep your worksite and the public safe around live sites
- ▶ A closed loop recycling product: made using recycled PVC
- ▶ Able to be returned to Oxford Plastics to be fully recycled



	STRONGWALL®	STRONGFENCE
	Product No.	0193 (Base), 0629 (Top)
Width	555mm	555mm
Length	1025mm	1025mm
Height	1000mm	2065mm
Weight	22kg	25.5kg
Quantity / Pallet	18	18
Colour	Black & Orange	Black, Orange & Silver

- StrongFence assembled 81kg
- StrongWall assembled 74kg
- Repairable

DROPBLOCK

BARRIER BALLAST WEIGHT

The DropBlock from Oxford Plastics is an alternative to sandbags. This robust ballast hooks onto barriers, fences and temporary signage to protect them against high winds.

PRODUCT RANGE



DROPBLOCK

Usage Benefits

- ▶ Robust alternative to sandbags
- ▶ Compatible with pedestrian barriers, fencing and signage
- ▶ 9kg weight ensures high wind resistance
- ▶ Eliminates sand and debris on the worksite
- ▶ Made of a tough recycled plastic
- ▶ Can be recycled at end of life
- ▶ Easy-carry handholds
- ▶ Stackable for ease of transport and storage
- ▶ Pedestrian-friendly high visibility inserts
- ▶ Not suitable for road-facing applications

	DROPBLOCK
Product No.	O274
Width	250mm
Length	98mm
Height	395mm
Weight	9kg
Quantity / Pallet	50
Colour	Black & Yellow

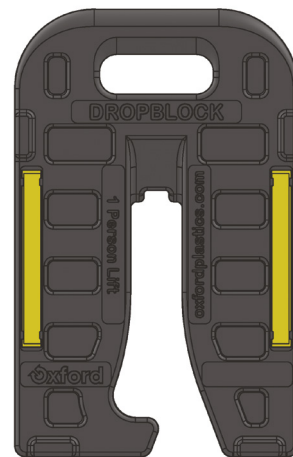

SAFEGATE®

MANHOLE BARRIER

The SafeGate barrier is designed for use around temporary excavations and is commonly used in the communications industry.

PRODUCT RANGE



SAFEGATE®

Usage Benefits

- ▶ Portable solution making it easier to carry & deploy than typical Chapter 8 barriers
- ▶ Lightweight, which keeps overall vehicle weight low, and allows for easy installation
- ▶ Keep sites protected in high wind conditions by using the SafeBase
- ▶ Clearly cordon off areas to reduce the danger of pedestrians/site staff entering restricted zones
- ▶ Ability to reinforce social distancing measures
- ▶ Can be configured in a square or in a line with the SafeBase and patented locking system
- ▶ Able to be returned to Oxford Plastics to be fully recycled

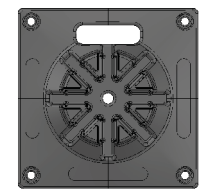
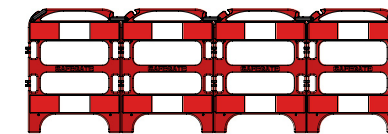
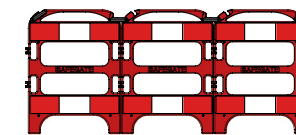

	SAFEGATE®		SAFEBASE
	3 WAY BARRIER	4 WAY BARRIER	
Product No.	O9737	O9738	O204
Width	60mm	80mm	340mm
Length	2250mm	3000mm	340mm
Height	1000mm	1000mm	80mm
Weight	6kg	8kg	2.6kg
Quantity / Pallet	25	20	150
Colour	Red/Yellow	Red/Yellow	Black



OXFORDWALL™

DEMARCATIION

Water-filled barrier which is hi-vis for traffic delineation, and is fast and easy to deploy.

PRODUCT RANGE



OXFORDWALL™

Usage Benefits

- ▶ Withstands high winds when water-filled to increase barrier weight up to 20kg
- ▶ Heavy, durable solution for robust installations
- ▶ Lightweight (when empty) for easy transport and storage by 1 person
- ▶ Create hi-vis barrier systems that won't fade
- ▶ Easy to carry internal handholds which also increase wind-resistance
- ▶ Clearly define access and thoroughfares in high traffic area
- ▶ Ensures mandated physical distance measures
- ▶ Protect site staff and pedestrians against risk factors
- ▶ Able to be returned to Oxford Plastics to be fully recycled

	OXFORDWALL™
Product No.	O9169
Width	395mm
Length	1100mm
Height	600mm
Weight	8kg
Quantity / Pallet	18
Colour	White & Red

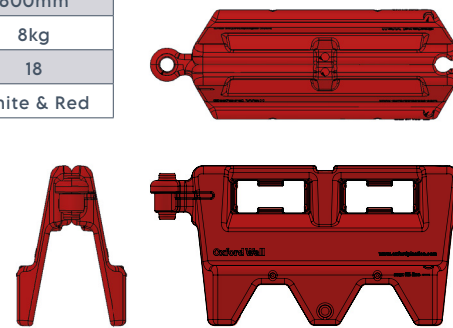

FENCE PIN

FENCING

Fence Pins protect staff from the danger of being electrocuted, compared to a metal fence pin. The Fence Pin is non-conductive and suitable for sites with electric cable hazards.

PRODUCT RANGE



FENCE PIN

Usage Benefits

- ▶ A durable non-conductive component to create temporary fencing
- ▶ Lightweight and easy to assemble a perimeter
- ▶ Use in dry and wet ground conditions
- ▶ Able to be returned to Oxford Plastics to be fully recycled

	FENCE PIN
Product No.	O514
Width	18mm
Length	1400mm
Height	18mm
Weight	0.5kg
Quantity / Pallet	500
Colour	White & Silver





Traffic Management

Like all products from Oxford Plastics, our Traffic Management range is designed for safety and ease of use. Whether you need temporary equipment for a work site, or a more permanent fixture for facilities management – we’ve got you covered.

High visibility is essential when it comes to creating safe throughways. This is why we use only British Standard reflective. Oxford Plastics understand safety, which is why we build high visibility inserts and long-lasting colours into our products. So you can be confident that your site can be clearly seen in all weather.

As experts in recycled materials and durability, Oxford Plastics build recycled plastics into all products where possible. We use hard-wearing and long-lasting recycled plastic.

BRITISH STANDARD



REFLECTIVE

DURABLE RECYCLED MATERIAL



HIGH WIND



RESISTANCE

CUSTOMISABLE



ENDURASIGN QUICKFIT FRAME®

TEMPORARY SIGNS

The EnduraSign QuickFit Frame is a recycled plastic sign frame that is compatible with 300mm hole centre sign faces.

The modular design means the correct signage can be quickly assembled on site. Space and weight limitations are improved in works vehicles compared to using single piece Chapter 8 signs.

PRODUCT RANGE



ENDURASIGN QUICKFIT FRAME® & BALLAST WEIGHT

Usage Benefits

- ▶ Ultra-durable sign frame is resistant to cracking
- ▶ Plastic sign frame fitted with 4 antiluce droplocks, compatible with 300mm spaced quickfit faces
- ▶ Compact design to fit more signage in works vehicles
- ▶ Interchangeable sign faces can be installed on site
- ▶ Highly resistant to wind
- ▶ Category C (19 mph) winds without ballast
- ▶ Category B (39 mph) winds with a 9kg weight (for 1050 rectangle use 13kg)
- ▶ Compatible with EnduraSign Ballast 9kg weight
- ▶ Lightweight 3.3kg design reduces weight in works vehicles
- ▶ Clearly label equipment and prevent theft with a corporate nameplate and custom RAL colour frame
- ▶ Create clear signage and information in all weather
- ▶ EnduraBallast replaces sandbags, avoids debris and trip hazards. It's also A closed loop recycling product: made of recycled PVC & fully recyclable

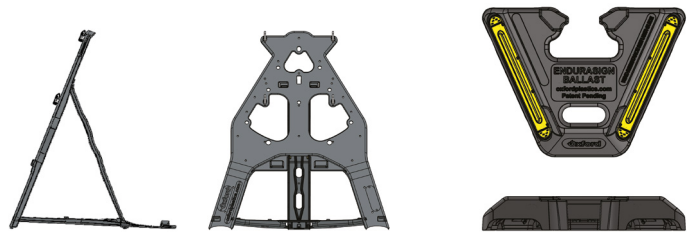

	ENDURASIGN	
	QUICKFIT FRAME®	BALLAST WEIGHT
Product No.	O424	O426
Width	35mm	556mm
Length	800mm	407mm
Height	870mm	90mm
Weight	3.3kg	10kg
Quantity / Pallet	50	60
Colour	Black, custom RAL colours MOQ	Black & Yellow



ENDURAFRAME™ 1500

TEMPORARY SIGNS

The EnduraFrame 1500 is a plastic quickfit mini sign frame that is compatible with standard 300mm centre quickfit sign faces.

This compact frame is lighter, thinner and more durable than metal and plastic equivalents. Space and weight limitations are improved in works vehicles compared to using single piece chapter 8 signs.

PRODUCT RANGE

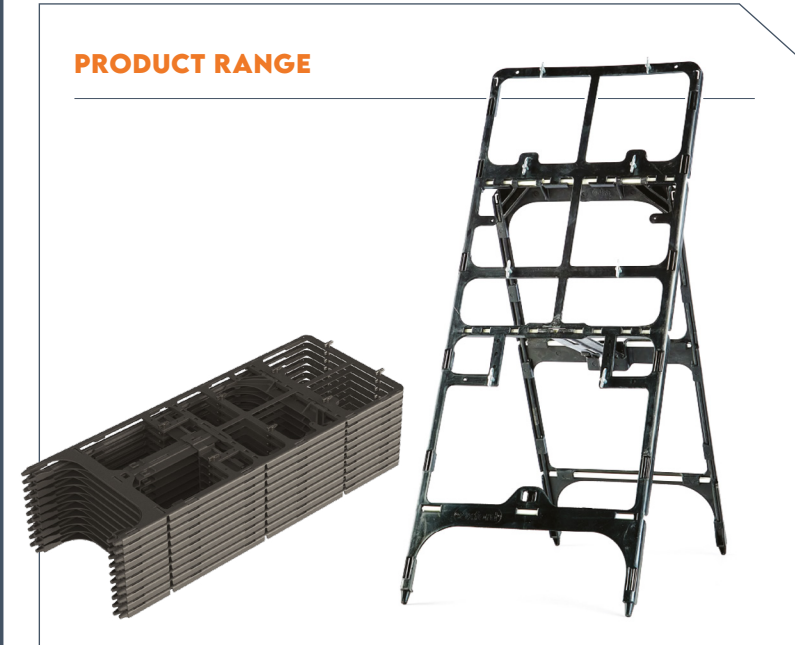

ENDURAFRAME™ 1500

Usage Benefits

- ▶ Made of ultra durable plastic with stiff composites which is resistant to cracking
- ▶ Fitted with 8 antiluce droplocks, compatible with 300mm spaced quickfit faces
- ▶ Compact design stacks efficiently: each sign is just 38mm wide when stacked
- ▶ Interchangeable sign faces and damaged faces can be changed on site
- ▶ Highly wind resistant
- ▶ Light 5kg design reduces weight in works vehicles compared to steel alternatives
- ▶ Does not collapse when left unattended due to the Intelligent leg lock design
- ▶ Clearly label equipment and prevent theft with corporate nameplate and custom RAL colour frame
- ▶ Repairable, spare parts are available
- ▶ Can be returned at end of life for recycling or reuse

	ENDURAFRAME™ 1500
Product No.	O492
Width	600mm
Length	62mm
Height	1495mm
Weight	5kg
Quantity / Pallet	50
Colour	Black, custom RAL colours MOQ





Mats and Ground Protection

Oxford Plastics have a range of ground protection solutions for temporary, semi-permanent and permanent uses.

We mould anti-slip surfaces into our products, providing a grippy surface that won't fade over time. Our mats and grids are made for both vehicle and pedestrian access. The range is designed to provide safe passageway for all traffic, particularly in wet and muddy situations.

Oxford Plastics have developed a suite of accessories to make your site safe and sound, including parking delineator inserts for the EnduraGrid, and heavy-duty connectors for the EnduraMat.

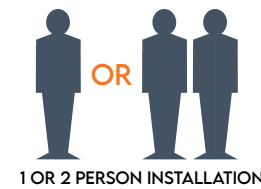

CUSTOMISABLE



**SLIP RESISTANT
IN WET**



**SLIP RESISTANT
IN DRY**



ENDURAMAT™ 2440

GROUND PROTECTION MAT

Heavy duty ground protection mat suitable for worksites, events and creating temporary access. The EnduraMat has a small grip on the top and a large grip on the bottom, making it suitable for vehicle access and pedestrian access.

PRODUCT RANGE

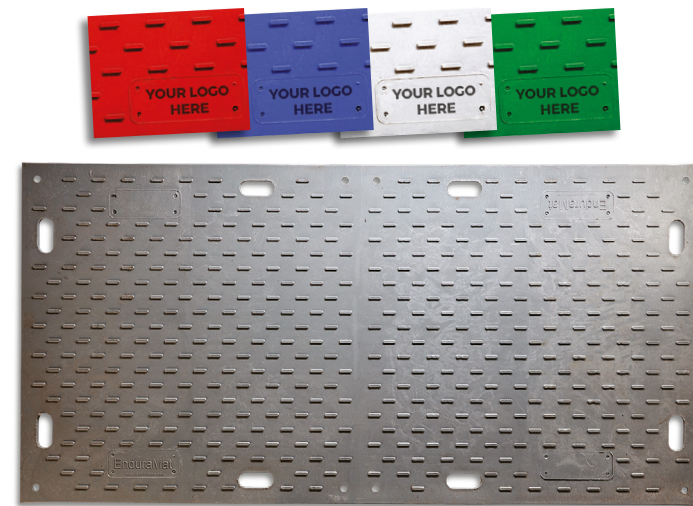

ENDURAMAT™ 2440

Usage Benefits

- ▶ Clearly demarcate walkways and thoroughfares to avoid hazards
- ▶ Create stable ground conditions for heavy vehicles
- ▶ Clearly signpost to inform, educate and navigate pedestrians
- ▶ Create semi-permanent roadways using heavy-duty couplers
- ▶ Create clear passageways to help reinforce social distancing measures
- ▶ Create portable roadways using light-duty couplers
- ▶ Enquire about minimum order quantities for customisations
- ▶ Made from recycled material and can be returned at end of life for recycling or reuse

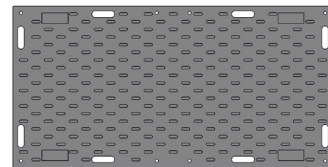

	ENDURAMAT™ 2440		
	ENDURAMAT™ 2440	COUPLER HEAVY DUTY	COUPLER LIGHT DUTY
Product No.	0651	0648	0652
Width	1220mm	178mm	132mm
Length	2440mm	178mm	95mm
Height	12mm	8mm	3mm
Weight	32kg	2kg	0.2kg
Quantity / Pallet	20	100	100
Colour	Grey / Black	Silver	Silver



73kg



ENDURAMAT™ 2400

GROUND PROTECTION MAT

The EnduraMat 2400 is a ground protection mat for temporary access.

The reversible tread pattern suits pedestrian and vehicle traffic.

Compatible with a wide range of connectors and other metric sized ground protection mats.

PRODUCT RANGE

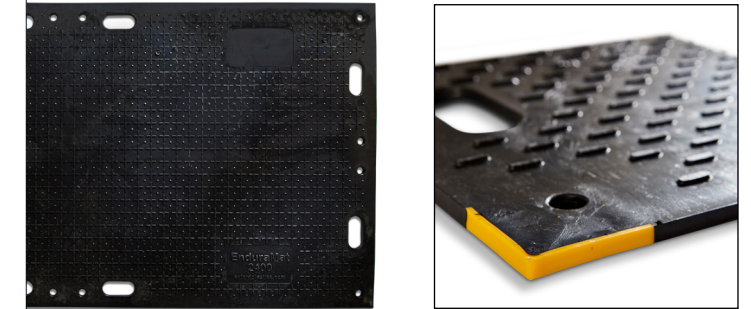

ENDURAMAT™ 2400

Usage Benefits

- ▶ Compatible with a wide range of connectors
- ▶ Easy to use alongside existing ground mat stock
- ▶ Use Oxford Plastics' light-duty connectors for quick installations
- ▶ Use Oxford Plastics' heavy-duty 4-way connectors for long-term projects and heavy traffic
- ▶ 8 handholds around the edge of each mat for ease of carrying and installation
- ▶ Reversible anti-slip tread pattern for pedestrians and vehicles
- ▶ Made of ultra durable recycled plastic
- ▶ Black or grey as standard, other RAL colours available with virgin material
- ▶ Clearly label equipment and prevent theft with corporate logo embossing and custom RAL colours
- ▶ Made from recycled material and can be returned at end of life for recycling or reuse
- ▶ Available with coloured edges

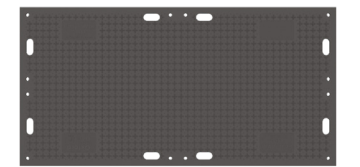

	ENDURAMAT™ 2400		
	ENDURAMAT™ 2400	COUPLER HEAVY DUTY	COUPLER LIGHT DUTY
Product No.	0751	0648	0652
Width	1200mm	178mm	132mm
Length	2400mm	178mm	95mm
Height	18mm	8mm	3mm
Weight	35kg	2kg	0.2kg
Quantity / Pallet	30	100	100
Colour	Black / Grey	Silver	Silver



73kg

CLEARPATH® MAT

TEMPORARY WALKWAY

Create raised passageways with this pedestrian mat made of tough plastic for work sites, events and temporary crossings.

PRODUCT RANGE



CLEARPATH® MAT

Usage Benefits

- ▶ Lightweight and durable solution for easy installation
- ▶ Can be easily installed, transported and stored
- ▶ Provide added stability on uneven ground
- ▶ Ability to reinforce social distancing measures
- ▶ Clearly cordon off areas to reduce the risk of pedestrians/site staff entering restricted zones
- ▶ A closed loop recycling product: made of recycled PVC
- ▶ Fully recyclable

	CLEARPATH® MAT
Product No.	O329
Width	1200mm
Length	600mm
Height	22mm
Weight	20kg
Quantity / Pallet	30
Colour	Black



74kg

ENDURAGRID™

GROUND PROTECTION

EnduraGrid is an interlocking porous paving system designed to reinforce the ground. Perfect for carparks, driveways, paths, patios and muddy areas.

PRODUCT RANGE

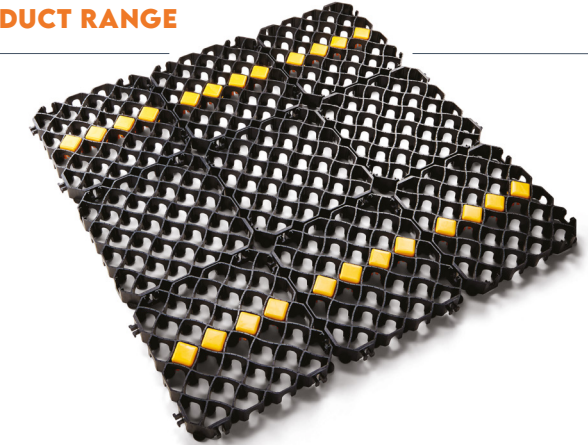

ENDURAGRID™

Usage Benefits

- ▶ Create permanent ground protection grids
- ▶ Lightweight and durable for easy transport and installation by 1 person
- ▶ Interlock the paving system to reinforce the ground
- ▶ Support vehicles up to 44 tonnes depending on ground conditions
- ▶ Parking marker spots slot into the grid to demarcate car park spaces
- ▶ Install up to 3900ft² per hour
- ▶ Protect car parks, driveways, paths and soft/muddy ground
- ▶ Create long-lasting porous ground protection areas that work all year round
- ▶ Cutaways permit grass root growth to keep lawns looking green
- ▶ Curved lattice structure creates a flat surface: the grid allows for expanding and contracting in hot weather to prevent the surface from rounding up
- ▶ Fully recyclable

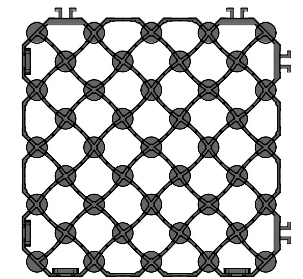

	ENDURAGRID™	CARPARK MARKER
Product No.	O681	O684
Width	500mm	69mm
Length	500mm	69mm
Height	65mm	68mm
Weight	2kg	00
Quantity / Pallet	120	White / Yellow
Colour	Black	Yellow



EnduraGrid
8kg



Fence Feet and Heavy Bases

Our fence feet and heavy bases are first and foremost effective, durable and safe for use on construction sites and at high profile sporting and entertainment events.

Their high-visibility ends are patent protected to keep your work site safe by reducing the risk of trips and falls.

Oxford Plastics is one of the biggest users of recycled PVC in the world and in 2019 we used 16% of all the recycled PVC in the UK.

We go to great lengths to use recycled materials in our products – none more so than with our fence feet and heavy bases – and at the end of their life most of these can be re-ground into new products.

DURABLE RECYCLED MATERIAL



HIGH VISIBILITY



PATENT PROTECTED



CUSTOMISABLE



OXSTAND®

FENCING

The OxStand is an alternative to the metal tube stand, commonly used with metal fencing at events and on construction sites. You can stack and carry multiple OxStands at a time, drastically reducing installation labour time and cost.

PRODUCT RANGE



OXSTAND®

Usage Benefits

- ▶ Can be easily installed, transported and stored
- ▶ Use with the Temporary Fence Weight to provide weighted stability across fencing systems
- ▶ Reduce cost and installation labour time
- ▶ Carry multiple OxStands at once for ease of installation
- ▶ Reduce trip hazards with these highly visible fence stands

	OXSTAND®
Product No.	O614
Width	305mm
Length	920mm
Height	184mm
Weight	3kg
Quantity / Pallet	130
Colour	Black & Yellow

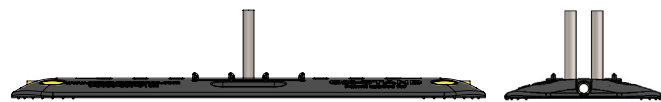
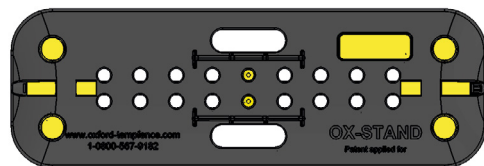

Repairable

TEMPORARY FENCE WEIGHT

FENCING

The Temporary Fence Weight is a high-visibility ballast weight for temporary fencing. The alternative to sandbags, which does not decompose or leak sand onto pavements and work sites. The Temporary Fence Weight ballasts fence panels to create a long lasting, wind-resistant perimeter.

PRODUCT RANGE



TEMPORARY FENCE WEIGHT

Usage Benefits

- ▶ Create a wind resistant fence perimeter for construction sites and events
- ▶ Eliminate sand bags which decompose and create mess
- ▶ Carry multiple Temporary Fence Weights at once using the internal handles
- ▶ Create an anti-trip walkway using this low-profile and hi-vis ballast
- ▶ Stack and secure Temporary Fence Weights on top of metal tube stands and OxStand to create a semi-permanent fence line
- ▶ Generate more revenue than single use sandbags
- ▶ A closed loop recycling product: made of recycled PVC

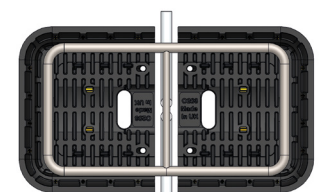
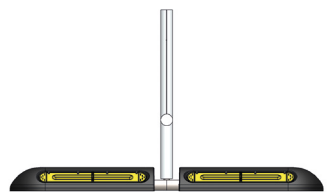
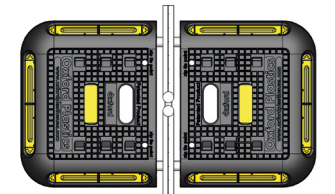

	FENCE WEIGHT
Product No.	O203
Width	600mm
Length	495mm
Height	70mm
Weight	13.6kg
Quantity / Pallet	72
Colour	Black & Yellow



49kg

OXBLOCK

FENCING

This heavy base forms a stable base for metal and plastic security fencing. The OxBlock is the best alternative to concrete blocks. It is made from a tough thermoplastic compound that is shock and crack resistant.

PRODUCT RANGE



OXBLOCK

Usage Benefits

- ▶ Can be easily stored and transported using the internal handles
- ▶ Provide added visibility for workers, spectators or pedestrians with hi-vis ends
- ▶ A versatile and durable component that can be used with a range of fencing
- ▶ A closed loop recycling product: made of recycled PVC
- ▶ Create enhanced stability of fencing systems to maintain demarcation and social distancing
- ▶ Fully recyclable
- ▶ Reduce trip hazards with these low-profile, compact fence feet
- ▶ Can reinforce contractor, client or project branding, as required

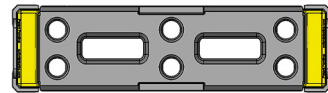

	OXBLOCK FENCEFOOT			
	15KG HIVIS	18KG HIVIZ	24KG HIVIZ	26KG HIVIZ
Product No.	O207	O225	O253	O201
Width	193mm	205mm	210mm	245mm
Length	770mm	770mm	775mm	680mm
Height	135mm	128mm	154mm	150mm
Weight	15kg	18kg	24kg	26kg
Quantity / Pallet	48	48	42	
Colour	Black & Yellow	Black & Yellow	Black & Yellow	Black



Repairable

SOLE BOARD

SCAFFOLDING BOARD

Sole board is for use with scaffolding installations, replacing timber scaffolding board base plates which deteriorate and splinter. Place 1 sole board under each scaffold base to create a stable structure and to protect the ground underneath.

The high-visibility anti-trip design ensures that worksites are safe for workers and pedestrians.

PRODUCT RANGE



SOLE BOARD

Usage Benefits

- ▶ Distributes the load of scaffolding
- ▶ Gives stability and safety for scaffolding on soft ground
- ▶ Suitable for 15T loads on flat, level ground
- ▶ Internal base plate size 165 x 165mm
- ▶ Replaces timber scaffolding board base plates
- ▶ Low profile design minimises trip hazards to pedestrians and workers
- ▶ Large 1.5m² footprint
- ▶ Non-conductive
- ▶ High-visibility and UV resistant colour
- ▶ Fully recyclable

	SOLE BOARD
Product No.	O630
Width	300mm
Length	500mm
Height	77mm
Weight	1.7kg
Quantity / Pallet	200
Colour	Yellow

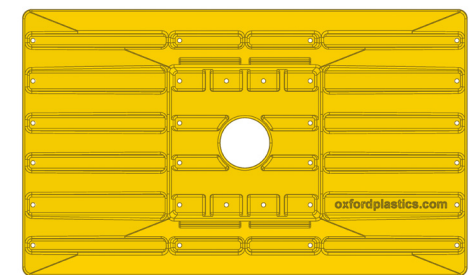
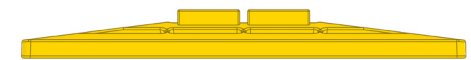

4kg

SQUARE BASE

FENCE POST BASE

Durable heavy duty post base available with 4 hole sizes. A versatile ecological heavy base which can fit 4 sizes of post: 40mm, 44mm, 51mm and 60mm. The handle means it is easy to transport.

PRODUCT RANGE



SQUARE BASE

Usage Benefits

- ▶ Can be easily installed, transported and stored using moulded handles
- ▶ Provide weighted stability and shock resistance across fencing systems
- ▶ Support fence poles of 40mm, 44mm, 51mm and 60mm
- ▶ Reduce trip hazards with these long-lasting square fence feet
- ▶ Adapt and customise fence feet with corporate logo
- ▶ A closed loop recycling product: made of recycled PVC
- ▶ Fully recyclable

	SQUARE BASE
Product No.	O151
Width	415mm
Length	415mm
Height	100mm
Weight	9kg
Quantity / Pallet	75
Colour	Black

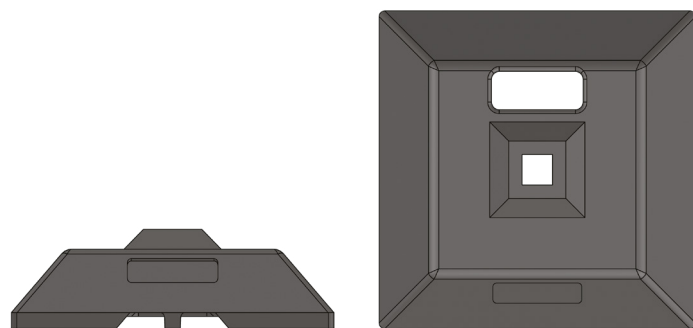

OCTAGONAL BASE

FENCE FEET

Heavy duty base with 3 hole sizes and shapes (40mm, 45mm and 80mm), suitable for signs and fencing. A cost-effective alternative to concrete bases, the thermoplastic compound is more resistant to cracking and damage.

PRODUCT RANGE



OCTAGONAL BASE

Usage Benefits

- ▶ Can be easily installed, transported and stored using moulded handles
- ▶ Provide weighted stability and shock resistance across fencing systems
- ▶ Reduce trip hazards with these long-lasting fence feet
- ▶ Adapt and customise fence feet with corporate logo
- ▶ A closed loop recycling product: made of recycled PVC
- ▶ Fully recyclable

	OCTAGONAL BASE
Product No.	O326
Width	502mm
Length	502mm
Height	110mm
Weight	20kg
Quantity / Pallet	36
Colour	Black

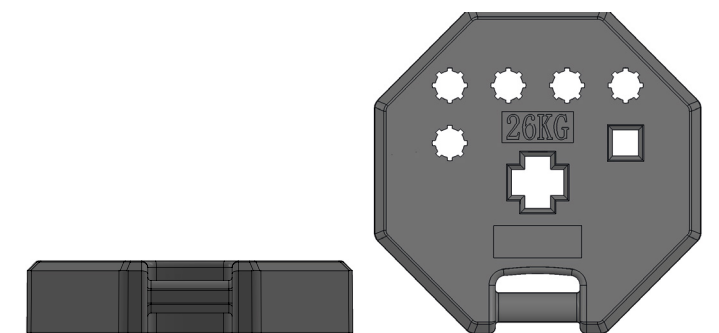

EURO BASE

FENCE FEET

Heavy duty base with 3 hole sizes and shapes (42mm and 62mm), suitable for signs and fencing. A cost-effective alternative to concrete bases, the thermoplastic compound is more resistant to cracking and damage.

PRODUCT RANGE

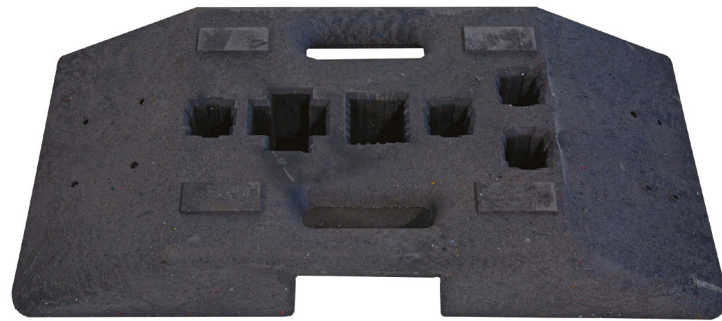

EURO BASE

Usage Benefits

- ▶ Can be easily installed, transported and stored using moulded handles
- ▶ Provide weighted stability and shock resistance across fencing systems
- ▶ Reduce trip hazards with these long-lasting fence feet
- ▶ Adapt and customise fence feet with corporate logo
- ▶ A closed loop recycling product: made of recycled PVC
- ▶ Fully recyclable

	OCTAGONAL BASE
Product No.	O221
Width	390mm
Length	790mm
Height	122mm
Weight	20kg
Quantity / Pallet	36
Colour	Black

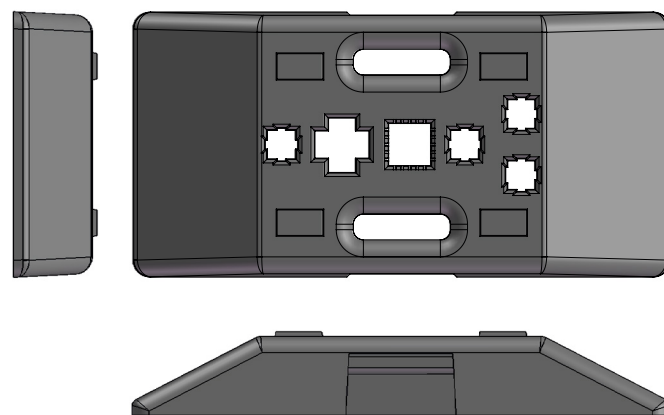

Contact us

OXFORD PLASTIC SYSTEMS LTD

Unit T2, Enstone Business Park
Enstone, Chipping Norton
Oxfordshire
OX7 4NP
United Kingdom

FIND YOUR NEAREST STOCKIST TODAY:

Call Us: +44 (0) 1608 678888
Email Us: sales@oxfordplastics.com
Find us online: www.oxfordplastics.com



